

### Carbide 鎢鋼材質

- CE** 超微粒鎢鋼 0.8u m/m Co10%  
Micro Grain 0.8u m/m Co10%
- 2D** 超微粒鎢鋼 0.6u m/m Co10%  
Micro Grain 0.6u m/m Co10%
- 2** 超微粒鎢鋼 0.6u m/m Co10%  
Micro Grain 0.6u m/m Co10%
- 5** 極細超微粒鎢鋼 0.3u m/m Co12%  
Super Micro Grain 0.3u m/m Co12%
- 638** 極細超微粒鎢鋼 0.3u m/m Co8%  
Super Micro Grain 0.3u m/m Co8%

### Coating 塗層

- TXM** 適用於一般加工、溼式切削  
Good at for wet cutting
- R7** 適用於一般加工、溼式切削  
Good at for wet cutting
- SF** 適用於一般加工、溼式切削  
Good at for wet cutting
- OL** 適用於一般加工，乾、溼兩用  
Good at for wet cutting . For dry & wet cutting
- TX** 適用於難切削材高速加工，乾、溼兩用  
Good at difficult material. For dry & wet cutting
- GR** 適用於難切削材高速加工，乾、溼兩用  
Good at difficult material. For dry & wet cutting
- NB** 適用於高速高硬度，乾式切削  
Good at high speed cutting & high hard cutting. For dry cutting
- OS** 適用於高速高硬度，乾式切削  
Good at high speed cutting & high hard cutting. For dry cutting

### Helix Angle 螺旋角



螺旋角是 20° 35° 40° 45° 50° 55° 5° 20° 30° 35° 45°  
Helix Angle is 20° 35° 40° 45° 50° 55° 5° 20° 30° 35° 45°

### Shank 柄部精度



### Work Material Hardness 可加工硬度



被切削工件硬度達 HRC35,HRC45,HRC52,HRC55,HRC62,HRC65  
Work Material Hardnes is up to HRC35,HRC45,HRC52,HRC55,HRC62,HRC65

### 高效率加工用銑刀

Milling Cutters for High Efficiency Machining

#### >>> 產品零件加工用刀

Milling cutters for product parts processing



**N** 有色金屬系列 THE COLOER SERIES  
使用超微粒 0.8u m/m Co10% 鎢鋼製成，搭配特有的幾何角度特殊切刃設計，特別適用於有色金屬，鋁鎂合金以及銅合金之專用銑刀。



**S** 耐熱合金系列 THE HEAT RESISTANT ALLOY SERIES  
使用超微粒 0.6u m/m Co10% 鎢鋼製成，搭配特有的幾何角度特殊切刃設計，特別適用於合金鋼、工具鋼、不鏽鋼、鈦合金、耐熱合金鋼、鍍基合金專用銑刀。

#### >>> 模具用刀

Milling cutter for mold



**2** 太陽戰士系列 THE SUN SERIES  
使用超微粒 0.6u m/m Co10% 鎢鋼製成，搭配TXM 高潤滑性塗層，適用於溼式加工，碳素鋼、合金鋼 ~HRC45 之鋼材、不鏽鋼、鈦合金廣泛運用。



**5** 黃金戰神系列 THE CLOUD SERIES  
使用極細超微粒 0.3u m/m Co12% 鎢鋼製成，搭配高耐熱及高潤滑性之TX級塗層，特別適用於溼式高速切削、合金鋼、模具鋼~HRC58 之鋼材。





**638** 藍天鬥神系列 THE BLUE SKY SERIES  
使用極細超微粒 0.3u m/m Co8% 鎢鋼製成，搭配高耐熱、高耐磨NB塗層，特別適用於合金鋼、模具鋼 HRC45~HRC68 之高速高硬度乾式加工。

# INDEX

系列	產品編號	切削工具	刃數	刀具名稱	頁數	
高效能防震系列	EAVD		4T	高效能防震鎢鋼立銑刀	6	
	EALD		4T	高效能長刃防震鎢鋼立銑刀	7	
	ERVD		4T	高效能防震鎢鋼立銑刀	8	
	ERLD		4T	高效能長刃防震鎢鋼立銑刀	9	
	MLERVD		4T	高效能長柄防震鎢鋼立銑刀	10	
	ERVR		4T	高效能防震鎢鋼R角立銑刀	11	
	SEW		4T	高效能防震波浪型刀	12	
	2PE3		3T	鎢鋼立銑刀	13	
	MHR		4T	鎢鋼粗銑刀	14	
	CED		4T	高效率防震鎢鋼立銑刀	15	
	CEB		2T	高效率鎢鋼精密球刀	16	
	CER		4T	高效率鎢鋼R角銑刀	17	
	鋁銅合金專用系列	AED		3T	戰鬥機鋁合金專用鎢鋼立銑刀	19
		AEW		3T	波浪鋁用刀	19
AEC			3T	鋁合金專用鎢鋼立銑刀	20	
AELC			3T	鋁合金專用長刃鎢鋼立銑刀	21	
AE			3T	龍捲風鋁合金專用鎢鋼立銑刀	22	
SLAE			3T	龍捲風鋁合金專用長柄鎢鋼立銑刀	23	
AEL			3T	龍捲風鋁合金專用長刃鎢鋼立銑刀	24	
ACB			2T	鋁銅專用鎢鋼球刀	26	
SLACB			2T	鋁銅專用長柄鎢鋼球刀	27	
AR			3T	鋁銅專用鎢鋼R角銑刀	28	
SLAR			3T	鋁銅專用長柄鎢鋼R角銑刀	30	
一般鋼材泛用加工		2MPE		4T	重切削鎢鋼立銑刀	31
		2MHD		4T	重切削鎢鋼立銑刀	31
		2SLE4		4T	長柄鎢鋼立銑刀	32
	2LET4		4T	長刃鎢鋼立銑刀	34	
	2SE2		2T	鎢鋼立銑刀	35	

# INDEX

系列	產品編號	切削工具	刃數	刀具名稱	頁數	
一般鋼材泛用加工	2SE2		2T	點數鎢鋼立銑刀	36	
	2MSB2		2T	鎢鋼球刀	39	
	2SLB2		2T	長柄鎢鋼球刀	40	
	2RTA		4T	鎢鋼R角銑刀	42	
	2SLR4		4T	長柄鎢鋼R角銑刀	44	
	模具加工專用	5MSE		4T	重切削鎢鋼立銑刀	46
		5MHD		4T	重切削鎢鋼立銑刀	46
		5MSE2		2T	小徑鎢鋼立銑刀	47
		5SLE4		4T	長柄鎢鋼立銑刀	48
		5LET4		4T	長刃鎢鋼立銑刀	50
		5SB2		2T	鎢鋼球刀	52
		5MSB		2T	小徑鎢鋼球刀	53
		5SLB2		2T	長柄鎢鋼球刀	54
		5RTA		4T	鎢鋼R角銑刀	56
5SLR4			4T	長柄鎢鋼R角銑刀	58	
5LNT			2T	深溝加工用鎢鋼立銑刀	60	
5LNB			2T	深溝加工用鎢鋼球刀	61	
5LNR			4T	深溝加工用鎢鋼R角銑刀	62	
熱處理乾式專用		638MSE4		4T	高速·高硬度專用鎢鋼立銑刀	64
	638SE4		4T	高速·高硬度專用鎢鋼立銑刀	64	
	638MSE2		2T	高速·高硬度專用小徑鎢鋼立銑刀	65	
	638MSE2		2T	高速·高硬度專用鎢鋼立銑刀	66	
	638SE2		2T	高速·高硬度專用鎢鋼立銑刀	66	
	638MSP6		6T	高速·高硬度專用鎢鋼立銑刀	67	
	638MLP6		6T	高速·高硬度專用鎢鋼長刃立銑刀	67	
	638SB2		2T	高速·高硬度專用鎢鋼球刀	68	
	638MSB2		2T	高速·高硬度專用小徑鎢鋼球刀	69	

# INDEX

系列	產品編號	切削工具	刃數	刀具名稱	頁數
熱處理乾式專用	638SLB2		2T	高速・高硬度專用長柄鎢鋼球刀	70
	638RTA		4T	高速・高硬度專用鎢鋼 R 角銑刀	72
	638SLR		4T	高速・高硬度專用長柄鎢鋼 R 角銑刀	74
車銑複合機專用	TMAE		3T	車銑複合機專用鋁用立銑刀	76
	TMTAE		3T	車銑複合機專用鋁用小柄銑刀	76
	TMSB		2T	車銑複合機專用鎢鋼球型銑刀	77
	TMTSB		2T	車銑複合機專用小柄球銑刀	77
	TMPE		3T	車銑複合機專用立銑刀	78
	TMTPE		3T	車銑複合機專用小柄立銑刀	78
	螺紋加工	VUA		3T	鎢鋼螺旋銑牙刀 (三峰)
VUB			3T/4T	鎢鋼螺旋銑牙刀 (全齒)	79
VUA			3T	鎢鋼銑牙刀 - UN 內牙/外牙 (三峰)	80
VUB			3T/4T	鎢鋼銑牙刀 - UN 內牙	81
VUC			3T	鎢鋼螺旋斜度銑牙刀	82
倒角與特殊加工	22R2WC		2T/4T	鎢鋼倒角刀	83
	22R2UD		4T	鎢鋼上下倒角刀	84
	V22SD		2T	鎢鋼鑽銑刀	85
	SDNCWC		2T	鎢鋼定位鑽	86
	5TTA		1T	鎢鋼雕刻銑刀	86
	RC		4T	鎢鋼外 R 角銑刀	87
	5MTB		2T	鎢鋼棒棒糖球刀-280°	87
	638XXE		X	碳纖維專用鎢鋼銑刀 - XX刀	88
	638YYE		4T	碳纖維專用鎢鋼銑刀 - YY刀	88
	2TE		4T/6T	鎢鋼 T 型銑刀	89
	CBTE			焊刀鎢鋼 T 型槽銑刀 (直刃)	90
	2RJ		4T	鎢鋼鳩尾刀 - 45° / 60°	91
	5TTA		2T/4T	鎢鋼斜度銑刀	92

# INDEX

系列	產品編號	切削工具	刃數	刀具名稱	頁數
鎢鋼刀頭	HESD		4T	鎖牙鎢鋼平刀頭	96
	HSB		2T	鎖牙鎢鋼球刀頭	96
	HESR		4T	鎖牙鎢鋼 R 角刀頭	96
	HAE		3T	鎖牙鋁合金平刀頭	97
	HACB		2T	鎖牙鋁合金球刀頭	97
	HAR		3T	鎖牙鋁合金 R 角刀頭	97
	鎢鋼刀柄	GL			鎢鋼抗震刀柄
HDC/HUC				鎢鋼後拉刀桿	102
HDC/HUC				後拉筒夾	103
GLCK				鎢鋼抗震搪刀柄	104
小徑車刀	MPR			微型車刀	106
	MGR			微型車刀 (切槽)	106
	MIR			微型車刀 (60° 螺紋加工)	107
鎢鋼鑽頭	HQDEXZ		2T	鎢鋼平底鑽頭	108
				鎢鋼直柄短刃鑽頭	109
				鎢鋼直柄長刃鑽頭	110
				鎢鋼銑刀柄機械鉸刀	111
				鎢鋼直柄機械鉸刀	112
手工工具系列				HSS 高速鋼星型六角起子頭	116
				HSS 高速鋼十字起子頭	116
				HSS 高速鋼六角起子頭	117
				HSS 高速鋼捨棄式刀具專用星型起子	118
				專利走心式車床專用螺帽棘輪扳手	119
				專利走心式車床專用星型棘輪扳手	119
				鎢鋼倒角起子頭	120

## 2 EAVD 高效能防震鎢鋼立銑刀

EAVD (Highly-Efficiency Anti-Vibration Operation Type), 4 Flutes

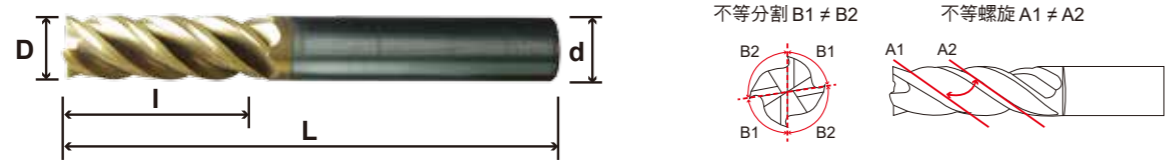

單位：mm (Unit : mm)

產品編號 Model No.	刃徑 D Diameter	刃長 l Flute Length	柄徑 d Shank Diameter	全長 L Overall Length	價格 Price	備註
2 EAVD 0204TX	2	6	4	50		
2 EAVD 0254TX	2.5	8	4	50		
2 EAVD 0304TX	3	8	4	50		
2 EAVD 0304TXD6	3	8	6	50		
2 EAVD 0404TX	4	11	4	50		
2 EAVD 0404TXD6	4	11	6	50		
2 EAVD 0504TX	5	13	6	50		
2 EAVD 0604TX	6	18	6	50		
2 EAVD 0704TX	7	21	8	60		
2 EAVD 0804TX	8	20	8	60		
2 EAVD 0804TXS24	8	24	8	60		
2 EAVD 0904TX	9	25	10	75		
2 EAVD 1004TX	10	30	10	75		
2 EAVD 1104TX	11	30	12	75		
2 EAVD 1204TX	12	30	12	75		
2 EAVD 1204TXS36	12	36	12	75		
2 EAVD 1604TX	16	50	16	100		
2 EAVD 2004TX	20	50	20	100		

備註：其他規格，請來電洽詢。

適用材質：

★最適合 ●適合 ▲佳

碳素鋼 Carbon steels	合金鋼 Alloy steel	預硬鋼材 Pre-hardened steels ~HRC45	高硬度鋼 High-hardened					不銹鋼 Stainless steels	鈦合金 Titanium alloys	鎳基合金 Nickel Based alloys	銅合金 Copper alloys	鋁合金 Aluminum alloys
			~HRC50	~HRC55	~HRC60	~HRC65						
★	★	●	▲				●			●	▲	

## 2 EALD 高效能長刃防震鎢鋼立銑刀

EALD (Highly-Efficiency Anti-Vibration Operation, Long Flute Length), 4 Flutes

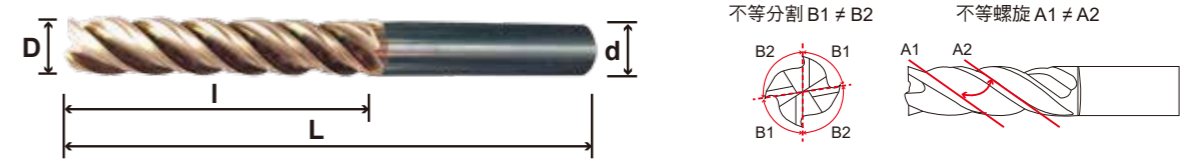

單位：mm (Unit : mm)

產品編號 Model No.	刃徑 D Diameter	刃長 l Flute Length	柄徑 d Shank Diameter	全長 L Overall Length	價格 Price	備註
2 EALD 0304TXD6	3	15	6	50		
2 EALD 0404TXD6	4	20	6	75		
2 EALD 0504TX	5	25	6	75		
2 EALD 0604TX	6	30	6	75		
2 EALD 0704TX	7	35	8	100		
2 EALD 0804TX	8	40	8	100		
2 EALD 0904TX	9	45	10	100		
2 EALD 1004TX	10	50	10	100		
2 EALD 1204TX	12	50	12	100		
2 EALD 1604TX	16	80	16	150		
2 EALD 2004TX	20	80	20	150		

備註：其他規格，請來電洽詢。

適用材質：

★最適合 ●適合 ▲佳

碳素鋼 Carbon steels	合金鋼 Alloy steel	預硬鋼材 Pre-hardened steels ~HRC45	高硬度鋼 High-hardened					不銹鋼 Stainless steels	鈦合金 Titanium alloys	鎳基合金 Nickel Based alloys	銅合金 Copper alloys	鋁合金 Aluminum alloys
			~HRC50	~HRC55	~HRC60	~HRC65						
★	★	●	▲				●			●	▲	

## 2D ERVD 高效能防震鎢鋼立銑刀

ERVD (Highly-Efficiency & Anti-Vibration Operation Type), 4 Flutes

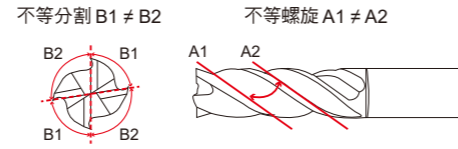
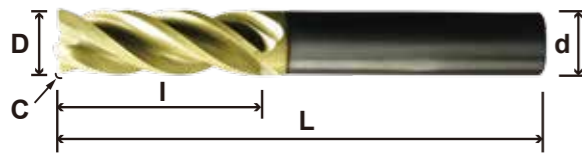

單位：mm (Unit : mm)

產品編號 Model No.	刃徑 D Diameter	刃長 I Flute Length	倒角 C Chamfer	柄徑 d Shank Diameter	全長 L Overall Length	價格 Price	備註
2D ERVD 0104GR	1	2.5		4	50		
2D ERVD 0154GR	1.5	4		4	50		
2D ERVD 0204GR	2	6		4	50		
2D ERVD 0254GR	2.5	7		4	50		
2D ERVD 0304GR	3	8		6	50		
2D ERVD 0404GR	4	11		6	50		
2D ERVD 0504GR	5	13		6	50		
2D ERVD 0604GR	6	15	0.2	6	50		
2D ERVD 0604GRS18	6	18	0.2	6	50		
2D ERVD 0704GR	7	18	0.2	8	60		
2D ERVD 0804GR	8	20	0.2	8	60		
2D ERVD 0804GRS24	8	24	0.2	8	60		
2D ERVD 0904GR	9	25	0.2	10	75		
2D ERVD 1004GR	10	30	0.2	10	75		
2D ERVD 1104GR	11	30	0.2	12	75		
2D ERVD 1204GR	12	30	0.2	12	75		
2D ERVD 1204GRS36	12	36	0.2	12	75		
2D ERVD 1404GR	14	35	0.2	16	100		
2D ERVD 1604GRS45	16	45	0.2	16	100		
2D ERVD 1604GR	16	50	0.2	16	100		
2D ERVD 2004GR	20	50	0.2	20	100		

備註：其他規格，請來電洽詢。

適用材質：

★最適合 ●適合 ▲佳

碳素鋼 Carbon steels	合金鋼 Alloy steel	預硬鋼材 Pre-hardened steels ~HRC45	高硬度鋼 High-hardened					不銹鋼 Stainless steels	鈦合金 Titanium alloys	鎳基合金 Nickel Based alloys	銅合金 Copper alloys	鋁合金 Aluminum alloys
			~HRC50	~HRC55	~HRC60	~HRC65						
★	★	●	▲				★	★	●	●	▲	

## 2D ERLD 高效能長刃防震鎢鋼立銑刀

ERLD (Highly-Efficiency Anti-Vibration Operation, Long Flute Length), 4 Flutes

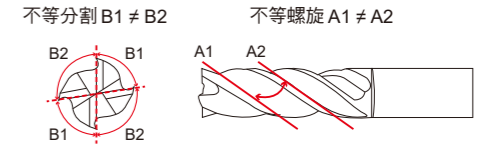

單位：mm (Unit : mm)

產品編號 Model No.	刃徑 D Diameter	刃長 I Flute Length	倒角 C Chamfer	柄徑 d Shank Diameter	全長 L Overall Length	價格 Price	備註
2D ERLD 0104GR	1	5		4	50		
2D ERLD 0154GR	1.5	8		4	50		
2D ERLD 0204GRD6	2	10		6	50		
2D ERLD 0254GRD6	2.5	13		6	50		
2D ERLD 0304GRD6	3	15		6	50		
2D ERLD 0404GRD6	4	20		6	75		
2D ERLD 0504GR	5	25		6	75		
2D ERLD 0604GR	6	30	0.2	6	75		
2D ERLD 0704GR	7	35	0.2	8	100		
2D ERLD 0804GR	8	40	0.2	8	100		
2D ERLD 0904GR	9	45	0.2	10	100		
2D ERLD 1004GR	10	50	0.2	10	100		
2D ERLD 1204GR	12	50	0.2	12	100		
2D ERLD 1604GR	16	80	0.2	16	150		
2D ERLD 2004GR	20	80	0.2	20	150		

備註：其他規格，請來電洽詢。

適用材質：

★最適合 ●適合 ▲佳

碳素鋼 Carbon steels	合金鋼 Alloy steel	預硬鋼材 Pre-hardened steels ~HRC45	高硬度鋼 High-hardened					不銹鋼 Stainless steels	鈦合金 Titanium alloys	鎳基合金 Nickel Based alloys	銅合金 Copper alloys	鋁合金 Aluminum alloys
			~HRC50	~HRC55	~HRC60	~HRC65						
★	★	●	▲				★	★	●	●	▲	

**2D MLERVD 高效能長柄防震鎢鋼立銑刀**



MLERVD (Highly-Efficiency Anti-Vibration Operation Long Shank), 4 Flutes

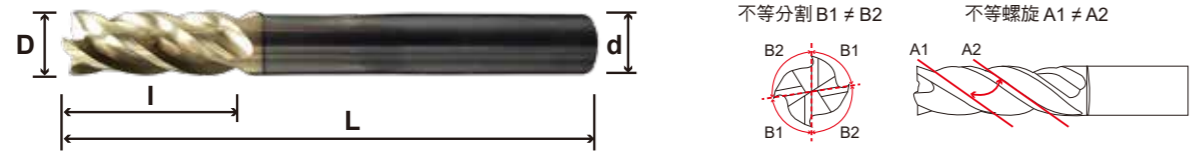

單位：mm (Unit : mm)

產品編號 Model No.	刃徑 D Diameter	刃長 l Flute Length	柄徑 d Shank Diameter	全長 L Overall Length	價格 Price	備註
2D SLERVD 0304GRD6	3	8	6	75		
2D MLERVD 0304GRD6	3	8	6	100		
2D SLERVD 0404GRD6	4	11	6	75		
2D MLERVD 0404GRD6	4	11	6	100		
2D SLERVD 0504GR	5	13	6	75		
2D MLERVD 0504GR	5	13	6	100		
2D SLERVD 0604GR	6	15	6	75		
2D MLERVD 0604GR	6	15	6	100		
2D MLERVD 0704GR	7	18	8	100		
2D SLERVD 0804GR	8	20	8	75		
2D MLERVD 0804GR	8	20	8	100		
2D MLERVD 0904GR	9	23	10	100		
2D MLERVD 1004GR	10	30	10	100		
2D MLERVD 1204GR	12	30	12	100		
2D MLERVD 1604GR	16	50	16	150		

備註：其他規格，請來電洽詢。

適用材質：

★最適合 ●適合 ▲佳

碳素鋼 Carbon steels	合金鋼 Alloy steel	預硬鋼材	高硬度鋼				不銹鋼 Stainless steels	鈦合金 Titanium alloys	鎳基合金 Nickel Based alloys	銅合金 Copper alloys	鋁合金 Aluminum alloys
		Pre-hardened steels	High-hardened								
		~HRC45	~HRC50	~HRC55	~HRC60	~HRC65					
★	★	●	▲				★	★	●	●	▲

**2D ERVR 高效能防震鎢鋼R角立銑刀**



ERVR (Highly-Efficiency & Anti-Vibration Operation Type Corner Radius), 4 Flutes



單位：mm (Unit : mm)

產品編號 Model No.	刃徑 × R角 D × R Diameter × Corner Radius	刃長 l Flute Length	柄徑 d Shank Diameter	全長 L Overall Length	價格 Price	備註
2D ERVR 020024GR	2 × 0.2R	6	6	50		
2D ERVR 020054GR	2 × 0.5R	6	6	50		
2D ERVR 025024GR	2.5 × 0.2R	7	6	50		
2D ERVR 025054GR	2.5 × 0.5R	7	6	50		
2D ERVR 030024GR	3 × 0.2R	8	6	50		
2D ERVR 030054GR	3 × 0.5R	8	6	50		
2D ERVR 030104GR	3 × 1R	8	6	50		
2D ERVR 040024GR	4 × 0.2R	11	6	50		
2D ERVR 040054GR	4 × 0.5R	11	6	50		
2D ERVR 040104GR	4 × 1R	11	6	50		
2D ERVR 050024GR	5 × 0.2R	13	6	50		
2D ERVR 050054GR	5 × 0.5R	13	6	50		
2D ERVR 050104GR	5 × 1R	13	6	50		
2D ERVR 060024GR	6 × 0.2R	15	6	50		
2D ERVR 060054GR	6 × 0.5R	15	6	50		
2D ERVR 060104GR	6 × 1R	15	6	50		
2D ERVR 080054GR	8 × 0.5R	20	8	60		
2D ERVR 080104GR	8 × 1R	20	8	60		
2D ERVR 100054GR	10 × 0.5R	30	10	75		
2D ERVR 100104GR	10 × 1R	30	10	75		
2D ERVR 100154GR	10 × 1.5R	30	10	75		
2D ERVR 100204GR	10 × 2R	30	10	75		
2D ERVR 100304GR	10 × 3R	30	10	75		
2D ERVR 120054GR	12 × 0.5R	30	12	75		
2D ERVR 120104GR	12 × 1R	30	12	75		
2D ERVR 120204GR	12 × 2R	30	12	75		
2D ERVR 160054GR	16 × 0.5R	50	16	100		
2D ERVR 160104GR	16 × 1R	50	16	100		
2D ERVR 160204GR	16 × 2R	50	16	100		
2D ERVR 160304GR	16 × 3R	50	16	100		
2D ERVR 200104GR	20 × 1R	50	20	100		
2D ERVR 200204GR	20 × 2R	50	20	100		
2D ERVR 200304GR	20 × 3R	50	20	100		

備註：其他規格，請來電洽詢。

適用材質：

★最適合 ●適合 ▲佳

碳素鋼 Carbon steels	合金鋼 Alloy steel	預硬鋼材	高硬度鋼				不銹鋼 Stainless steels	鈦合金 Titanium alloys	鎳基合金 Nickel Based alloys	銅合金 Copper alloys	鋁合金 Aluminum alloys
		Pre-hardened steels	High-hardened								
		~HRC45	~HRC50	~HRC55	~HRC60	~HRC65					
★	★	●	▲				★	★	●	●	▲

**2D SEW 高效能防震波浪型刀刃銑刀**

SEW (Highly-Efficiency & Anti-Vibration Operation, Wave Edge), 4 Flutes

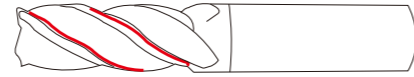
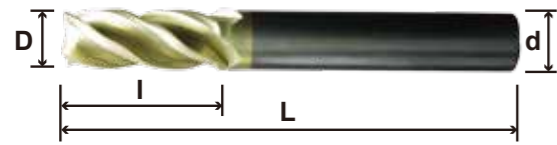

單位：mm (Unit : mm)

產品編號 Model No.	刃徑 D Diameter	刃長 l Flute Length	柄徑 d Shank Diameter	全長 L Overall Length	價格 Price	備註
2D SEW 0204GR	2	6	4	50		
2D SEW 0254GR	2.5	7	4	50		
2D SEW 0304GR	3	8	4	50		
2D SEW 0404GR	4	11	4	50		
2D SEW 0504GR	5	13	6	50		
2D SEW 0604GR	6	15	6	50		
2D SEW 0704GR	7	18	8	60		
2D SEW 0804GR	8	20	8	60		
2D SEW 0904GR	9	25	10	75		
2D SEW 1004GR	10	25	10	75		
2D SEW 1104GR	11	30	12	75		
2D SEW 1204GR	12	30	12	75		
2D SEW 1604GR	16	50	16	100		
2D SEW 2004GR	20	50	20	100		

備註：其他規格，請來電洽詢。

適用材質：

★最適合 ●適合 ▲佳

碳素鋼 Carbon steels	合金鋼 Alloy steel	預硬鋼材	高硬度鋼				不銹鋼 Stainless steels	鈦合金 Titanium alloys	鎳基合金 Nickel Based alloys	銅合金 Copper alloys	鋁合金 Aluminum alloys
		Pre-hardened steels	High-hardened								
		~HRC45	~HRC50	~HRC55	~HRC60	~HRC65					
★	★	●					★	★	●	●	●

**2 PE3 三刃鎢鋼立銑刀**

PE3 (Flat End Mill), 3 Flutes

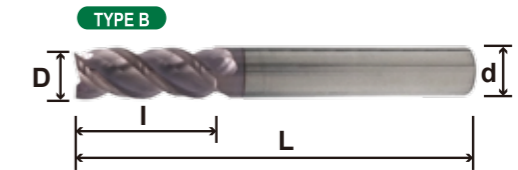
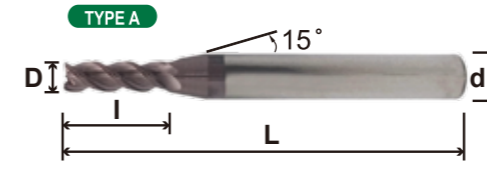

單位：mm (Unit : mm)

產品編號 Model No.	刃徑 D Diameter	刃長 l Flute Length	柄徑 d Shank Diameter	全長 L Overall Length	價格 Price	備註
2 PE 0103SF	1	3	6	50		
2 PE 0153SF	1.5	4	6	50		
2 PE 0203SF	2	6	6	50		
2 PE 0253SF	2.5	7	6	50		
2 PE 0303SF	3	9	6	50		
2 PE 0353SF	3.5	10	6	50		
2 PE 0403SF	4	12	6	50		
2 PE 0453SF	4.5	13	6	50		
2 PE 0503SF	5	13	6	50		
2 PE 0553SF	5.5	15	6	50		
2 PE 0603SF	6	15	6	50		
2 PE 0703SF	7	18	8	60		
2 PE 0753SF	7.5	20	8	60		
2 PE 0803SF	8	20	8	60		
2 PE 0903SF	9	23	10	75		
2 PE 1003SF	10	25	10	75		
2 PE 1103SF	11	30	12	75		
2 PE 1203SF	12	30	12	75		
2 PE 1403SF	14	40	16	100		
2 PE 1603SF	16	45	16	100		

備註：其他規格，請來電洽詢。

適用材質：

★最適合 ●適合 ▲佳

碳素鋼 Carbon steels	合金鋼 Alloy steel	預硬鋼材	高硬度鋼				不銹鋼 Stainless steels	鈦合金 Titanium alloys	鎳基合金 Nickel Based alloys	銅合金 Copper alloys	鋁合金 Aluminum alloys
		Pre-hardened steels	High-hardened								
		~HRC45	~HRC50	~HRC55	~HRC60	~HRC65					
★	★	●					★	●	●	●	

## 2 MHR 鎢鋼粗銑刀

MHR (Roughing End Mills), 4 Flutes



單位：mm (Unit : mm)

產品編號 Model No.	刃徑 D Diameter	刃長 l Flute Length	柄徑 d Shank Diameter	全長 L Overall Length	價格 Price	備註
2 MHR 0604TXM	6	15	6	50		
2 MHR 0804TXM	8	20	8	60		
2 MHR 1004TXM	10	25	10	75		
2 MHR 1204TXM	12	30	12	75		
2 MHR 1404TXM	14	40	16	100		
2 MHR 1604TXM	16	50	16	100		
2 MHR 2004TXM	20	50	20	100		

備註：其他規格，請來電洽詢。

適用材質：

★最適合 ●適合 ▲佳

碳素鋼 Carbon steels	合金鋼 Alloy steel	預硬鋼材 Pre-hardened steels					高硬度鋼 High-hardened					不銹鋼 Stainless steels	鈦合金 Titanium alloys	鎳基合金 Nickel Based alloys	銅合金 Copper alloys	鋁合金 Aluminum alloys
		~HRC45	~HRC50	~HRC55	~HRC60	~HRC65										
★	★	●	●				●	●				●	●			

## CE CED 高效率防震立銑刀

CED (Highly Efficient Operation), 4 Flutes

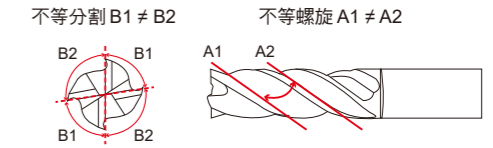

單位：mm (Unit : mm)

產品編號 Model No.	刃徑 D Diameter	刃長 l Flute Length	柄徑 d Shank Diameter	全長 L Overall Length	價格 Price	備註
CED 0104GR	1	3	4	50		
CED 0154GR	1.5	4.5	4	50		
CED 0204GR	2	6	4	50		
CED 0254GR	2.5	8	4	50		
CED 0304GR	3	9	4	50		
CED 0304GRD6	3	9	6	50		
CED 0404GR	4	12	4	50		
CED 0404GRD6	4	12	6	50		
CED 0504GR	5	15	6	50		
CED 0604GR	6	18	6	50		
CED 0804GR	8	24	8	60		
CED 1004GR	10	30	10	75		
CED 1204GR	12	36	12	75		
CED 1604GR	16	50	16	100		
CED 2004GR	20	50	20	100		

備註：其他規格，請來電洽詢。

適用材質：

★最適合 ●適合 ▲佳

碳素鋼 Carbon steels	合金鋼 Alloy steel	預硬鋼材 Pre-hardened steels					高硬度鋼 High-hardened					不銹鋼 Stainless steels	鈦合金 Titanium alloys	鎳基合金 Nickel Based alloys	銅合金 Copper alloys	鋁合金 Aluminum alloys
		~HRC45	~HRC50	~HRC55	~HRC60	~HRC65										
★	★	●									★	●		●	●	



### CEB 高效率精密球刀

CEB (Highly Efficient Operation, Ball Nose), 2 Flutes



單位：mm (Unit : mm)

產品編號 Model No.	球頭半徑 R Radius	刃徑 D Diameter	刃長 l Flute Length	柄徑 d Shank Diameter	全長 L Overall Length	價格 Price	備註
CEB 0102GR	0.5R	1	2	4	50		
CEB 0102GRD6	0.5R	1	2	6	50		
CEB 0152GR	0.75R	1.5	3	4	50		
CEB 0152GRD6	0.75R	1.5	3	6	50		
CEB 0202GR	1R	2	4	4	50		
CEB 0202GRD6	1R	2	4	6	50		
CEB 0302GRD3	1.5R	3	6	3	50		
CEB 0302GR	1.5R	3	6	4	50		
CEB 0302GRD6	1.5R	3	6	6	50		
CEB 0402GR	2R	4	8	4	50		
CEB 0402GRD6	2R	4	8	6	50		
CEB 0502GR	2.5R	5	10	6	50		
CEB 0602GR	3R	6	12	6	50		
CEB 0802GR	4R	8	16	8	60		
CEB 1002GR	5R	10	20	10	75		
CEB 1202GR	6R	12	24	12	75		

備註：其他規格，請來電洽詢。

適用材質：

★最適合 ●適合 ▲佳

碳素鋼 Carbon steels	合金鋼 Alloy steel	預硬鋼材 Pre-hardened steels		高硬度鋼 High-hardened			不銹鋼 Stainless steels	鈦合金 Titanium alloys	鎳基合金 Nickel Based alloys	銅合金 Copper alloys	鋁合金 Aluminum alloys
		~HRC45	~HRC50	~HRC55	~HRC60	~HRC65					
★	★	●					★	●		●	●

### CER 高效率R角銑刀

CER (Highly Efficient Operation, Corner Radius), 4 Flutes

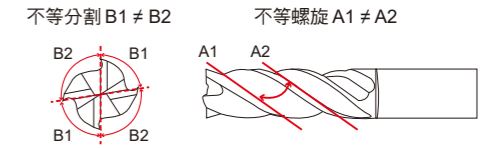
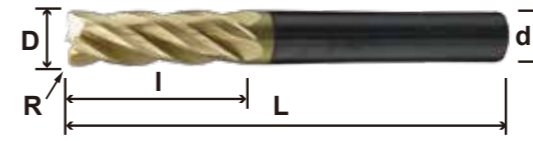

單位：mm (Unit : mm)

產品編號 Model No.	刃徑 × R角 D × R Diameter × Corner Radius	刃長 l Flute Length	柄徑 d Shank Diameter	全長 L Overall Length	價格 Price	備註
CER 010024GR	1 × 0.2R	3	4	50		
CER 015024GR	1.5 × 0.2R	4.5	4	50		
CER 015054GR	1.5 × 0.5R	4.5	4	50		
CER 020024GR	2 × 0.2R	6	4	50		
CER 020054GR	2 × 0.5R	6	4	50		
CER 025024GR	2.5 × 0.2R	7.5	4	50		
CER 025054GR	2.5 × 0.5R	7.5	4	50		
CER 030024GRD3	3 × 0.2R	9	3	50		
CER 030024GR	3 × 0.2R	9	4	50		
CER 030054GRD3	3 × 0.5R	9	3	50		
CER 030054GR	3 × 0.5R	9	4	50		
CER 030104GR	3 × 1R	9	4	50		
CER 040024GR	4 × 0.2R	12	4	50		
CER 040054GR	4 × 0.5R	12	4	50		
CER 040104GR	4 × 1R	12	4	50		
CER 060054GR	6 × 0.5R	18	6	50		
CER 060104GR	6 × 1R	18	6	50		
CER 080054GR	8 × 0.5R	24	8	60		
CER 080104GR	8 × 1R	24	8	60		
CER 100054GR	10 × 0.5R	30	10	75		
CER 100104GR	10 × 1R	30	10	75		
CER 120054GR	12 × 0.5R	36	12	75		
CER 120104GR	12 × 1R	36	12	75		
CER 120204GR	12 × 2R	36	12	75		

備註：其他規格，請來電洽詢。

適用材質：

★最適合 ●適合 ▲佳

碳素鋼 Carbon steels	合金鋼 Alloy steel	預硬鋼材 Pre-hardened steels		高硬度鋼 High-hardened			不銹鋼 Stainless steels	鈦合金 Titanium alloys	鎳基合金 Nickel Based alloys	銅合金 Copper alloys	鋁合金 Aluminum alloys
		~HRC45	~HRC50	~HRC55	~HRC60	~HRC65					
★	★	●					★	●		●	

# AE 系列鋁用立銑刀

## AE End Mills for Aluminum

**極** 致的垂直加工精度

Extreme verticality on machining

**優** 異的排屑性能

Excellent chip removal performance

**快** 速的進給速度

High speed for deep feed

**實** 現高速與精細的體現

Achieve high speed and fine performance



特別適用：鋁合金、銅合金、銅鋁合金

最好

很好

良好

好

Excellent

Best

Better

Good

專業 刀具 製造 廠

Specialized cutting tool factory

## 2 AED 戰鬥機鋁合金專用鎢鋼立銑刀

AED (For Aluminum Alloy), 3 Flutes



不等分割 B1 ≠ B2 ≠ B3



不等螺旋 A1 ≠ A2

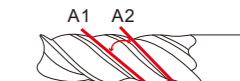

單位：mm (Unit : mm)

產品編號 Model No.	刃徑 D Diameter	刃長 l Flute Length	柄徑 d Shank Diameter	全長 L Overall Length	價格 Price	備註
2 AED 0303	3	10	6	50		
2 AED 0353	3.5	11	6	50		
2 AED 0403	4	12	6	50		
2 AED 0453	4.5	13	6	50		
2 AED 0503	5	15	6	50		
2 AED 0553	5.5	17	6	50		
2 AED 0603	6	18	6	50		
2 AED 0803	8	24	8	60		
2 AED 1003	10	30	10	75		
2 AED 1203	12	36	12	75		
2 AED 1603	16	50	16	100		
2 AED 2003	20	50	20	100		

## 2 AEW 波浪鋁用刀

AEW ( Aluminum End Mills - Wave Helix Blades Type ), 3 Flutes

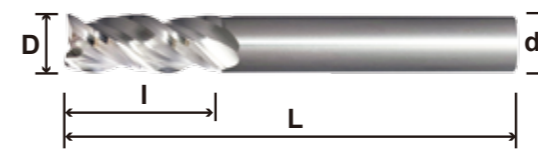

■ 高進給 high feed

■ 低負載 low load

單位：mm (Unit : mm)

產品編號 Model No.	刃徑 D Diameter	刃長 l Flute Length	柄徑 d Shank Diameter	全長 L Overall Length	價格 Price	備註
2 AEW 0603	6	16	6	50		
2 AEW 0803	8	20	8	60		
2 AEW 1003	10	25	10	75		
2 AEW 1203	12	30	12	75		
2 AEW 1603	16	45	16	100		
2 AEW 2003	20	50	20	100		

備註：其他規格，請來電洽詢。

適用材質：

★ 最適合 ● 適合 ▲ 佳

碳素鋼 Carbon steels	合金鋼 Alloy steel	預硬鋼材 Pre-hardened steels					高硬度鋼 High-hardened					不銹鋼 Stainless steels	鈦合金 Titanium alloys	鎳基合金 Nickel Based alloys	銅合金 Copper alloys	鋁合金 Aluminum alloys	
		~HRC45	~HRC50	~HRC55	~HRC60	~HRC65											
																★	★

特 性	垂直度	平滑度	效率
產品編號： <b>AE</b> 	▲	■	▲
產品編號： <b>AEC</b> 	●	●	■
產品編號： <b>AED</b> 	★	★	●
產品編號： <b>AEW</b> 	■	▲	★



## 2 AEC 鋁合金專用鎢鋼立銑刀

AEC (For Aluminum Alloy), 3 Flutes



極致的垂直加工精度。  
優異的排屑性能。  
快速的進給速度。  
實現高速與精細的體現。

單位：mm (Unit : mm)

產品編號 Model No.	刃徑 D Diameter	刃長 l Flute Length	柄徑 d Shank Diameter	全長 L Overall Length	價格 Price	備註
2 AEC 0103	1	3	4	50		
2 AEC 0153	1.5	5	4	50		
2 AEC 0203	2	6	4	50		
2 AEC 0203D6	2	6	6	50		
2 AEC 0253	2.5	8	4	50		
2 AEC 0253D6	2.5	8	6	50		
2 AEC 0303	3	9	4	50		
2 AEC 0303D6	3	9	6	50		
2 AEC 0403	4	12	4	50		
2 AEC 0403D6	4	12	6	50		
2 AEC 0503	5	15	6	50		
2 AEC 0603	6	18	6	50		
2 AEC 0703	7	21	8	60		
2 AEC 0803	8	24	8	60		
2 AEC 0903	9	27	10	75		
2 AEC 1003	10	30	10	75		
2 AEC 1103	11	33	12	75		
2 AEC 1203	12	36	12	75		
2 AEC 1403	14	45	14	100		
2 AEC 1603	16	50	16	100		
2 AEC 2003	20	50	20	100		

備註：其他規格，請來電洽詢。

適用材質：

★最適合 ●適合 ▲佳

碳素鋼 Carbon steels	合金鋼 Alloy steel	預硬鋼材 Pre-hardened steels ~HRC45	高硬度鋼 High-hardened				不銹鋼 Stainless steels	鈦合金 Titanium alloys	鎳基合金 Nickel Based alloys	銅合金 Copper alloys	鋁合金 Aluminum alloys
			~HRC50	~HRC55	~HRC60	~HRC65					
									★	★	

## 2 AELC 鋁合金專用長刃鎢鋼立銑刀

AELC (Long Flute Length, For Aluminum Alloy), 3 Flutes



單位：mm (Unit : mm)

產品編號 Model No.	刃徑 D Diameter	刃長 l Flute Length	柄徑 d Shank Diameter	全長 L Overall Length	價格 Price	備註
2 AELC 0103	1	5	6	50		
2 AELC 0153	1.5	8	6	50		
2 AELC 0203	2	10	6	50		
2 AELC 0203S12	2	12	6	50		
2 AELC 0303	3	15	6	50		
2 AELC 0403	4	20	6	75		
2 AELC 0403S25	4	25	6	75		
2 AELC 0503	5	25	6	75		
2 AELC 0603	6	30	6	75		
2 AELC 0603S40	6	40	6	100		
2 AELC 0603S50	6	50	6	100		
2 AELC 0703	7	35	8	100		
2 AELC 0803	8	40	8	100		
2 AELC 0803S50	8	50	8	100		
2 AELC 0903	9	45	10	100		
2 AELC 1003	10	50	10	100		
2 AELC 1003S60	10	60	10	100		
2 AELC 1103	11	50	12	100		
2 AELC 1203S50	12	50	12	100		
2 AELC 1203S60	12	60	12	100		
2 AELC 1603S65	16	65	16	120		
2 AELC 1603S80	16	80	16	150		
2 AELC 2003S65	20	65	20	120		
2 AELC 2003S80	20	80	20	150		

備註：其他規格，請來電洽詢。

適用材質：

★最適合 ●適合 ▲佳

碳素鋼 Carbon steels	合金鋼 Alloy steel	預硬鋼材 Pre-hardened steels ~HRC45	高硬度鋼 High-hardened				不銹鋼 Stainless steels	鈦合金 Titanium alloys	鎳基合金 Nickel Based alloys	銅合金 Copper alloys	鋁合金 Aluminum alloys
			~HRC50	~HRC55	~HRC60	~HRC65					
									★	★	

**2 AE 龍捲風鋁合金專用三刃鎢鋼立銑刀**

AE (For Aluminum Alloy), 3 Flutes

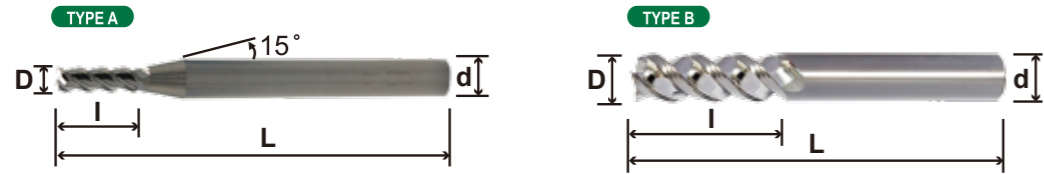

■ 大 切 深 . 高 進 給 . 加 工 面 精 細

單位 : mm (Unit : mm)

產品編號 Model No.	刃徑 D Diameter	刃長 l Flute Length	柄徑 d Shank Diameter	全長 L Overall Length	價格 Price	備註
2 AE 0103	1	3	4	50		
2 AE 0153	1.5	4.5	4	50		
2 AE 0203	2	6	4	50		
2 AE 0203D6	2	6	6	50		
2 AE 0253	2.5	8	4	50		
2 AE 0253D6	2.5	8	6	50		
2 AE 0303D3	3	10	3	50		
2 AE 0303	3	10	4	50		
2 AE 0303D6	3	10	6	50		
2 AE 0353	3.5	11	4	50		
2 AE 0353D6	3.5	11	6	50		
2 AE 0403	4	12	4	50		
2 AE 0403D6	4	12	6	50		
2 AE 0453	4.5	13	6	50		
2 AE 0503	5	15	6	50		
2 AE 0603	6	18	6	50		
2 AE 0703	7	21	8	60		
2 AE 0803	8	24	8	60		
2 AE 0903	9	27	10	75		
2 AE 1003	10	30	10	75		
2 AE 1103	11	33	12	75		
2 AE 1203	12	36	12	75		
2 AE 1403	14	45	14	100		
2 AE 1603	16	50	16	100		
2 AE 2003	20	50	20	100		

備註：其他規格，請來電洽詢。

適用材質：

★最適合 ●適合 ▲佳

碳素鋼 Carbon steels	合金鋼 Alloy steel	預硬鋼材	高硬度鋼				不銹鋼 Stainless steels	鈦合金 Titanium alloys	鎳基合金 Nickel Based alloys	銅合金 Copper alloys	鋁合金 Aluminum alloys
		Pre-hardened steels ~HRC45	~HRC50	~HRC55	~HRC60	~HRC65					
									★	★	

**2 SLAE / MLAE 龍捲風鋁合金專用三刃長柄鎢鋼立銑刀**

SLAE / MLAE (Long Shank, For Aluminum Alloy), 3 Flutes



單位 : mm (Unit : mm)

產品編號 Model No.	刃徑 D Diameter	刃長 l Flute Length	柄徑 d Shank Diameter	全長 L Overall Length	價格 Price	備註
2 SLAE 0403	4	12	4	75		
2 SLAE 0503	5	15	6	75		
2 SLAE 0603	6	18	6	75		
2 MLAE 0603	6	18	6	100		
2 SLAE 0803	8	24	8	75		
2 MLAE 0803	8	24	8	100		
2 MLAE 1003	10	30	10	100		
2 MLAE 1203	12	36	12	100		

備註：其他規格，請來電洽詢。

適用材質：

★最適合 ●適合 ▲佳

碳素鋼 Carbon steels	合金鋼 Alloy steel	預硬鋼材	高硬度鋼				不銹鋼 Stainless steels	鈦合金 Titanium alloys	鎳基合金 Nickel Based alloys	銅合金 Copper alloys	鋁合金 Aluminum alloys
		Pre-hardened steels ~HRC45	~HRC50	~HRC55	~HRC60	~HRC65					
										★	★

**2 AEL 龍捲風鋁合金專用三刃長刃鎢鋼立銑刀**   

AEL (Long Flute Length, For Aluminum Alloy), 3 Flutes



單位：mm (Unit : mm)

產品編號 Model No.	刃徑 D Diameter	刃長 l Flute Length	柄徑 d Shank Diameter	全長 L Overall Length	價格 Price	備註
2 AEL 0103D6	1	5	6	50		
2 AEL 0153D6	1.5	8	6	50		
2 AEL 0153S10D6	1.5	10	6	50		
2 AEL 0203D6	2	10	6	50		
2 AEL 0203S12D6	2	12	6	50		
2 AEL 0253D6S13	2.5	13	6	50		
2 AEL 0303D6	3	15	6	75		
2 AEL 0303D6S18	3	18	6	75		
2 AEL 0403D6S16	4	16	6	50		
2 AEL 0403	4	20	4	75		
2 AEL 0403D6	4	20	6	75		
2 AEL 0403D6S25	4	25	6	75		
2 AEL 0503S20	5	20	6	75		
2 AEL 0503	5	25	6	75		
2 AEL 0503S30	5	30	6	75		
2 AEL 0503S40	5	40	6	100		
2 AEL 0603S25L75	6	25	6	75		
2 AEL 0603S30L75	6	30	6	75		
2 AEL 0603S30L100	6	30	6	100		
2 AEL 0603S35L100	6	35	6	100		
2 AEL 0603S40L100	6	40	6	100		
2 AEL 0603S45L100	6	45	6	100		
2 AEL 0603S50L100	6	50	6	100		
2 AEL 0703S35L100	7	35	8	100		
2 AEL 0803S32	8	32	8	75		
2 AEL 0803S40L100	8	40	8	100		
2 AEL 0803S50L100	8	50	8	100		
2 AEL 0903	9	45	10	100		

備註：其他規格，請來電洽詢。

單位：mm (Unit : mm)

產品編號 Model No.	刃徑 D Diameter	刃長 l Flute Length	柄徑 d Shank Diameter	全長 L Overall Length	價格 Price	備註
2 AEL 1003S40	10	40	10	100		
2 AEL 1003S50	10	50	10	100		
2 AEL 1003S60	10	60	10	100		
2 AEL 1103	11	50	12	100		
2 AEL 1203S50	12	50	12	100		
2 AEL 1203S55	12	55	12	100		
2 AEL 1203S60	12	60	12	100		
2 AEL 1403	14	65	14	120		
2 AEL 1603S55	16	55	16	100		
2 AEL 1603S60	16	60	16	120		
2 AEL 1603S65	16	65	16	120		
2 AEL 1603S80	16	80	16	150		
2 AEL 1603S100	16	100	16	150		
2 AEL 2003S60	20	60	20	100		
2 AEL 2003S65	20	65	20	120		
2 AEL 2003S80	20	80	20	150		
2 AEL 2003S100	20	100	20	150		

備註：其他規格，請來電洽詢。

適用材質：

★最適合 ●適合 ▲佳

碳素鋼 Carbon steels	合金鋼 Alloy steel	預硬鋼材 Pre-hardened steels	高硬度鋼 High-hardened				不銹鋼 Stainless steels	鈦合金 Titanium alloys	鎳基合金 Nickel Based alloys	銅合金 Copper alloys	鋁合金 Aluminum alloys
		~HRC45	~HRC50	~HRC55	~HRC60	~HRC65					
										★	★

## 2 ACB 鋁銅專用二刃錐鋼球刀

ACB (Ball Nose, Aluminum Alloy), 2 Flutes

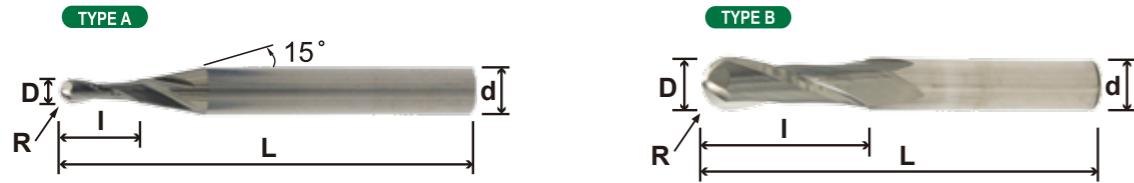

單位: mm (Unit : mm)

產品編號 Model No.	球頭半徑 R Radius	刃徑 D Diameter	刃長 l Flute Length	柄徑 d Shank Diameter	全長 L Overall Length	價格 Price	備註
2 ACB 0042	0.2R	0.4	1.2	4	50		
2 ACB 0052	0.25R	0.5	1.5	4	50		
2 ACB 0062	0.3R	0.6	1.8	4	50		
2 ACB 0082	0.4R	0.8	2.4	4	50		
2 ACB 0102	0.5R	1	3	4	50		
2 ACB 0152	0.75R	1.5	5	4	50		
2 ACB 0202	1R	2	6	4	50		
2 ACB 0252	1.25R	2.5	8	4	50		
2 ACB 0302D3	1.5R	3	10	3	50		
2 ACB 0302	1.5R	3	10	4	50		
2 ACB 0302D6	1.5R	3	10	6	50		
2 ACB 0402	2R	4	12	4	50		
2 ACB 0402D6	2R	4	12	6	50		
2 ACB 0502	2.5R	5	15	6	50		
2 ACB 0602	3R	6	18	6	50		
2 ACB 0802	4R	8	24	8	75		
2 ACB 1002	5R	10	30	10	75		
2 ACB 1202	6R	12	36	12	75		

備註: 其他規格, 請來電洽詢。

適用材質:

★最適合 ●適合 ▲佳

碳素鋼 Carbon steels	合金鋼 Alloy steel	預硬鋼材 Pre-hardened steels					高硬度鋼 High-hardened					不銹鋼 Stainless steels	鈦合金 Titanium alloys	鎳基合金 Nickel Based alloys	銅合金 Copper alloys	鋁合金 Aluminum alloys		
		~HRC45	~HRC50	~HRC55	~HRC60	~HRC65	~HRC50	~HRC55	~HRC60	~HRC65								
																	★	★

## 2 SLACB / MLACB / LLACB 鋁銅專用長柄錐鋼球刀

SLACB/MLACB/LLACB (Long Shank Ball Nose End Mill for Aluminum Alloy), 2 Flutes

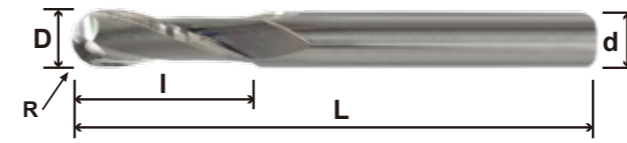

單位: mm (Unit : mm)

產品編號 Model No.	球頭半徑 R Radius	刃徑 D Diameter	刃長 l Flute Length	柄徑 d Shank Diameter	全長 L Overall Length	價格 Price	備註
2 SLACB 0102D6	0.5R	1	3	6	75		
2 MLACB 0102	0.5R	1	3	6	100		
2 SLACB 0152D6	0.75R	1.5	5	6	75		
2 MLACB 0152	0.75R	1.5	5	6	100		
2 SLACB 0202D6	1R	2	6	6	75		
2 MLACB 0202	1R	2	6	6	100		
2 SLACB 0302D6	1.5R	3	10	6	75		
2 MLACB 0302	1.5R	3	10	6	100		
2 SLACB 0402	2R	4	12	4	75		
2 SLACB 0402D6	2R	4	12	6	75		
2 MLACB 0402	2R	4	12	6	100		
2 SLACB 0502	2.5R	5	15	6	75		
2 MLACB 0502	2.5R	5	15	6	100		
2 SLACB 0602	3R	6	18	6	75		
2 MLACB 0602	3R	6	18	6	100		
2 SLACB 0802	4R	8	24	8	75		
2 MLACB 0802	4R	8	24	8	100		
2 LLACB 0802	4R	8	24	8	150		
2 MLACB 1002	5R	10	30	10	100		
2 LLACB 1002	5R	10	30	10	150		
2 MLACB 1202	6R	12	30	12	100		
2 LLACB 1202	6R	12	30	12	150		

備註: 其他規格, 請來電洽詢。

適用材質:

★最適合 ●適合 ▲佳

碳素鋼 Carbon steels	合金鋼 Alloy steel	預硬鋼材 Pre-hardened steels					高硬度鋼 High-hardened					不銹鋼 Stainless steels	鈦合金 Titanium alloys	鎳基合金 Nickel Based alloys	銅合金 Copper alloys	鋁合金 Aluminum alloys		
		~HRC45	~HRC50	~HRC55	~HRC60	~HRC65	~HRC50	~HRC55	~HRC60	~HRC65								
																	★	★

## 2 AR 鋁銅專用三刃鎢鋼R角銑刀

AR (Corner Radius, For Aluminum Alloy), 3 Flutes

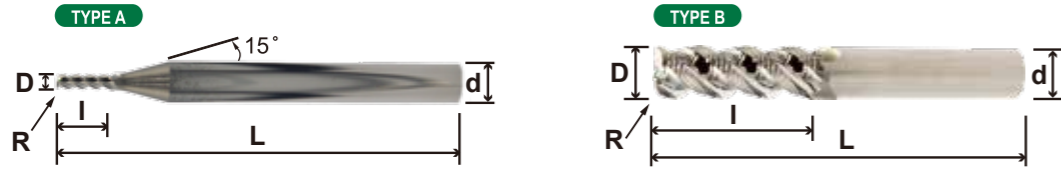

單位: mm (Unit: mm)

產品編號 Model No.	刃徑 D × R角 R Diameter × Corner Radius	刃長 I Flute Length	柄徑 d Shank Diameter	全長 L Overall Length	價格 Price	備註
2 AR 010023	1 × 0.2R	3	4	50		
2 AR 015023	1.5 × 0.2R	5	4	50		
2 AR 015053	1.5 × 0.5R	5	4	50		
2 AR 020023	2 × 0.2R	6	4	50		
2 AR 020053	2 × 0.5R	6	4	50		
2 AR 025023	2.5 × 0.2R	8	4	50		
2 AR 025053	2.5 × 0.5R	8	4	50		
2 AR 030023D3	3 × 0.2R	10	3	50		
2 AR 030023	3 × 0.2R	10	4	50		
2 AR 030053D3	3 × 0.5R	10	3	50		
2 AR 030053	3 × 0.5R	10	4	50		
2 AR 030053D6	3 × 0.5R	10	6	50		
2 AR 030103D3	3 × 1R	10	3	50		
2 AR 030103	3 × 1R	10	4	50		
2 AR 030103D6	3 × 1R	10	6	50		
2 AR 040023	4 × 0.2R	12	4	50		
2 AR 040053	4 × 0.5R	12	4	50		
2 AR 040053D6	4 × 0.5R	12	6	50		
2 AR 040103	4 × 1R	12	4	50		
2 AR 040103D6	4 × 1R	12	6	50		
2 AR 050053	5 × 0.5R	15	6	50		
2 AR 050103	5 × 1R	15	6	50		
2 AR 050153	5 × 1.5R	15	6	50		
2 AR 060023	6 × 0.2R	18	6	50		
2 AR 060053	6 × 0.5R	18	6	50		
2 AR 060103	6 × 1R	18	6	50		
2 AR 060153	6 × 1.5R	18	6	50		
2 AR 060203	6 × 2R	18	6	50		
2 AR 060253	6 × 2.5R	18	6	50		

單位: mm (Unit: mm)

產品編號 Model No.	刃徑 D × R角 R Diameter × Corner Radius	刃長 I Flute Length	柄徑 d Shank Diameter	全長 L Overall Length	價格 Price	備註
2 AR 080053	8 × 0.5R	24	8	60		
2 AR 080103	8 × 1R	24	8	60		
2 AR 080203	8 × 2R	24	8	60		
2 AR 080303	8 × 3R	24	8	60		
2 AR 100053	10 × 0.5R	30	10	75		
2 AR 100103	10 × 1R	30	10	75		
2 AR 100153	10 × 1.5R	30	10	75		
2 AR 100203	10 × 2R	30	10	75		
2 AR 100253	10 × 2.5R	30	10	75		
2 AR 100303	10 × 3R	30	10	75		
2 AR 100403	10 × 4R	30	10	75		
2 AR 120103	12 × 1R	36	12	75		
2 AR 120153	12 × 1.5R	36	12	75		
2 AR 120203	12 × 2R	36	12	75		
2 AR 120253	12 × 2.5R	36	12	75		
2 AR 120303	12 × 3R	36	12	75		
2 AR 120253	12 × 4R	36	12	75		
2 AR 140103	14 × 1R	45	14	100		
2 AR 140203	14 × 2R	45	14	100		
2 AR 140303	14 × 3R	45	14	100		
2 AR 160103	16 × 1R	50	16	100		
2 AR 160203	16 × 2R	50	16	100		
2 AR 160303	16 × 3R	50	16	100		
2 AR 160403	16 × 4R	50	16	100		
2 AR 160503	16 × 5R	50	16	100		
2 AR 200103	20 × 1R	50	20	100		
2 AR 200203	20 × 2R	50	20	100		
2 AR 200303	20 × 3R	50	20	100		
2 AR 200403	20 × 4R	50	20	100		
2 AR 200503	20 × 5R	50	20	100		

備註: 其他規格, 請來電洽詢。

適用材質:

★ 最適合 ● 適合 ▲ 佳

碳素鋼 Carbon steels	合金鋼 Alloy steel	預硬鋼材 Pre-hardened steels					高硬度鋼 High-hardened					不銹鋼 Stainless steels	鈦合金 Titanium alloys	鎳基合金 Nickel Based alloys	銅合金 Copper alloys	鋁合金 Aluminum alloys	
		~HRC45	~HRC50	~HRC55	~HRC60	~HRC65											
																★	★

## 2 SLAR / MLAR / LLAR 鋁銅專用長柄鎢鋼R角銑刀

SLAR/MLAR/LLAR (Long Shank Corner Radius, For Aluminum Alloy), 3 Flutes

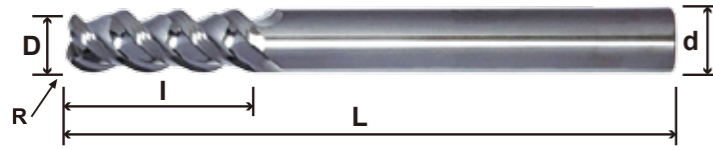

單位：mm (Unit : mm)

產品編號 Model No.	刃徑 D × R角 R Diameter × Corner Radius	刃長 l Flute Length	柄徑 d Shank Diameter	全長 L Overall Length	價格 Price	備註
2 SLAR 030023	3 × 0.2R	10	4	75		
2 SLAR 040023	4 × 0.2R	12	4	75		
2 SLAR 040053	4 × 0.5R	12	4	75		
2 SLAR 040103	4 × 1R	12	4	75		
2 SLAR 060023	6 × 0.2R	18	6	75		
2 SLAR 060103	6 × 1R	18	6	75		
2 MLAR 060103	6 × 1R	18	6	100		
2 SLAR 060203	6 × 2R	18	6	75		
2 SLAR 080023	8 × 0.2R	24	8	75		
2 SLAR 080053	8 × 0.5R	24	8	75		
2 SLAR 080103	8 × 1R	24	8	75		
2 SLAR 080153	8 × 1.5R	24	8	75		
2 SLAR 080203	8 × 2R	24	8	75		
2 SLAR 080253	8 × 2.5R	24	8	75		
2 SLAR 080303	8 × 3R	24	8	75		
2 MLAR 100103	10 × 1R	30	10	100		
2 LLAR 100303	10 × 3R	30	10	150		
2 MLAR 120153S30	12 × 1.5R	30	12	100		
2 LLAR 120103S30	12 × 1R	30	12	150		

備註：其他規格，請來電洽詢。

適用材質：

★最適合 ●適合 ▲佳

碳素鋼 Carbon steels	合金鋼 Alloy steel	預硬鋼材 Pre-hardened steels					高硬度鋼 High-hardened					不銹鋼 Stainless steels	鈦合金 Titanium alloys	鎳基合金 Nickel Based alloys	銅合金 Copper alloys	鋁合金 Aluminum alloys
		~HRC45	~HRC50	~HRC55	~HRC60	~HRC65	~HRC50	~HRC55	~HRC60	~HRC65						
															★	★

## 2 MHD 四刃重切削鎢鋼立銑刀

MHD (Heavy Cutting Operation Type), 4 Flutes

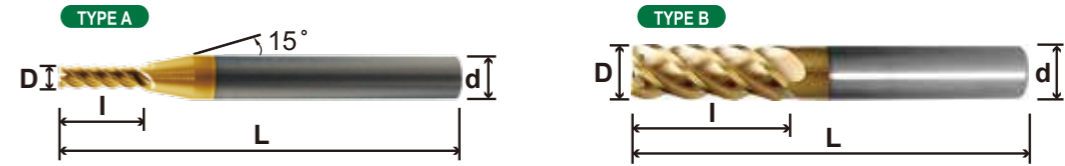

單位：mm (Unit : mm)

產品編號 Model No.	刃徑 D Diameter	刃長 l Flute Length	柄徑 d Shank Diameter	全長 L Overall Length	價格 Price	備註
2 MPE 0104TXM	1	3	4	50		
2 PE 0104TXM	1	3	6	50		
2 MPE 0154TXM	1.5	4	4	50		
2 PE 0154TXM	1.5	4	6	50		
2 MPE 0204TXM	2	6	4	50		
2 PE 0204TXM	2	6	6	50		
2 MPE 0254TXM	2.5	8	4	50		
2 PE 0254TXM	2.5	8	6	50		
2 MHD 0304TXMD3	3	8	3	50		
2 MHD 0304TXM	3	8	4	50		
2 MHD 0304TXMD6	3	8	6	50		
2 MHD 0354TXM	3.5	10	4	50		
2 MHD 0354TXMD6	3.5	10	6	50		
2 MHD 0404TXM	4	11	4	50		
2 MHD 0404TXMD6	4	11	6	50		
2 MHD 0454TXM	4.5	13	6	50		
2 MHD 0504TXM	5	13	6	50		
2 MHD 0554TXM	5.5	15	6	50		
2 MHD 0604TXM	6	16	6	50		
2 MHD 0654TXM	6.5	18	8	60		
2 MHD 0704TXM	7	18	8	60		
2 MHD 0754TXM	7.5	20	8	60		
2 MHD 0804TXM	8	20	8	60		
2 MHD 0854TXM	8.5	24	10	75		
2 MHD 0904TXM	9	23	10	75		
2 MHD 1004TXM	10	30	10	75		
2 MHD 1104TXM	11	28	12	75		
2 MHD 1204TXM	12	30	12	75		
2 MHD 1304TXM	13	40	16	100		
2 MHD 1404TXM	14	40	16	100		
2 MHD 1504TXM	15	45	16	100		
2 MHD 1604TXM	16	50	16	100		
2 MHD 1804TXM	18	50	20	100		
2 MHD 2004TXM	20	50	20	100		

備註：其他規格，請來電洽詢。

適用材質：

★最適合 ●適合 ▲佳

碳素鋼 Carbon steels	合金鋼 Alloy steel	預硬鋼材 Pre-hardened steels					高硬度鋼 High-hardened					不銹鋼 Stainless steels	鈦合金 Titanium alloys	鎳基合金 Nickel Based alloys	銅合金 Copper alloys	鋁合金 Aluminum alloys
		~HRC45	~HRC50	~HRC55	~HRC60	~HRC65	~HRC50	~HRC55	~HRC60	~HRC65						
★	★															



**2 SLE4 / MLE4 / LLE4 四刃長柄鎢鋼立銑刀** TXM 45 SHANK h5 HRC >45  
SLE4/MLE4/LLE4 (Long Shank, Regular Length), 4 Flutes

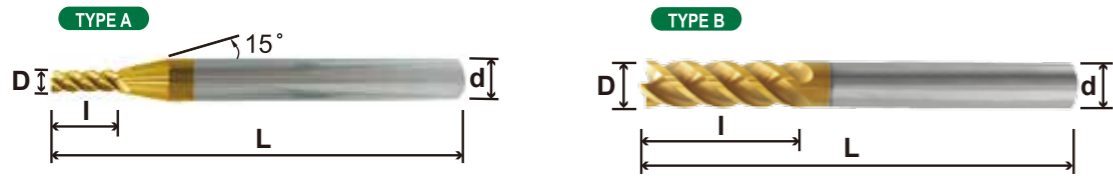

單位：mm (Unit : mm)

產品編號 Model No.	刃徑 D Diameter	刃長 l Flute Length	柄徑 d Shank Diameter	全長 L Overall Length	價格 Price	備註
2 SLE 0104TXMD6	1	2.5	6	75		
2 MLE 0104TXMD6	1	2.5	6	100		
2 SLE 0154TXMD6	1.5	4	6	75		
2 MLE 0154TXMD6	1.5	4	6	100		
2 SLE 0204TXMD6	2	6	6	75		
2 MLE 0204TXMD6	2	6	6	100		
2 SLE 0254TXMD6	2.5	7	6	75		
2 MLE 0254TXMD6	2.5	7	6	100		
2 SLE 0304TXMD3	3	8	3	75		
2 SLE 0304TXM	3	8	4	75		
2 SLE 0304TXMD6	3	8	6	75		
2 MLE 0304TXMD3	3	8	3	100		
2 MLE 0304TXM	3	8	4	100		
2 MLE 0304TXMD6	3	8	6	100		
2 SLE 0404TXM	4	11	4	75		
2 SLE 0404TXMD6	4	11	6	75		
2 MLE 0404TXM	4	11	4	100		
2 MLE 0404TXMD6	4	11	6	100		
2 SLE 0504TXM	5	13	6	75		
2 MLE 0504TXM	5	13	6	100		
2 SLE 0604TXM	6	16	6	75		
2 MLE 0604TXM	6	16	6	100		

單位：mm (Unit : mm)

產品編號 Model No.	刃徑 D Diameter	刃長 l Flute Length	柄徑 d Shank Diameter	全長 L Overall Length	價格 Price	備註
2 MLE 0704TXM	7	18	8	100		
2 SLE 0804TXM	8	20	8	75		
2 MLE 0804TXM	8	20	8	100		
2 LLE 0804TXM	8	20	8	150		
2 MLE 0904TXM	9	23	10	100		
2 MLE 1004TXM	10	30	10	100		
2 LLE 1004TXM	10	30	10	150		
2 MLE 1204TXM	12	30	12	100		
2 LLE 1204TXM	12	30	12	150		
2 MLE 1604TXM	16	50	16	150		
2 LLE 1604TXM	16	50	16	200		
2 MLE 2004TXM	20	50	20	150		
2 LLE 2004TXM	20	50	20	200		

備註：其他規格，請來電洽詢。

適用材質：

★最適合 ●適合 ▲佳

碳素鋼 Carbon steels	合金鋼 Alloy steel	預硬鋼材 Pre-hardened steels	高硬度鋼 High-hardened				不銹鋼 Stainless steels	鈦合金 Titanium alloys	鎳基合金 Nickel Based alloys	銅合金 Copper alloys	鋁合金 Aluminum alloys
		~HRC45	~HRC50	~HRC55	~HRC60	~HRC65					
★	★	●	▲				●			●	

## 2 LET4 四刃長刃鎢鋼立銑刀

LET4 (Long Flute Length End Mill), 4 Flutes

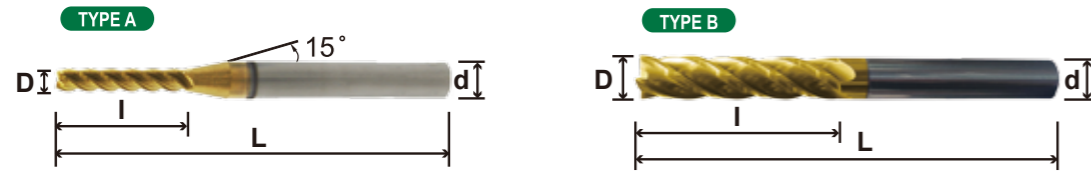

單位：mm (Unit : mm)

產品編號 Model No.	刃徑 D Diameter	刃長 l Flute Length	柄徑 d Shank Diameter	全長 L Overall Length	價格 Price	備註
2 LET 0104TXM	1	5	4	50		
2 LET 0154TXM	1.5	8	4	50		
2 LET 0204TXM	2	10	4	50		
2 LET 0254TXM	2.5	13	4	50		
2 LET 0304TXM	3	15	6	50		
2 LET 0404TXM	4	20	6	75		
2 LET 0504TXM	5	25	6	75		
2 LET 0604TXM	6	30	6	75		
2 LET 0704TXM	7	35	8	100		
2 LET 0804TXM	8	40	8	100		
2 LET 0904TXM	9	45	10	100		
2 LET 1004TXM	10	50	10	100		
2 LET 1204TXM	12	50	12	100		
2 LET 1604TXM	16	80	16	150		
2 LET 2004TXM	20	80	20	150		

備註：其他規格，請來電洽詢。

適用材質：

★最適合 ●適合 ▲佳

碳素鋼 Carbon steels	合金鋼 Alloy steel	預硬鋼材	高硬度鋼				不銹鋼 Stainless steels	鈦合金 Titanium alloys	鎳基合金 Nickel Based alloys	銅合金 Copper alloys	鋁合金 Aluminum alloys
		Pre-hardened steels	High-hardened								
★	★	~HRC45	~HRC50	~HRC55	~HRC60	~HRC65	●			●	

## 2 SE2 二刃鎢鋼立銑刀

SE2 (Regular Length), 2 Flutes

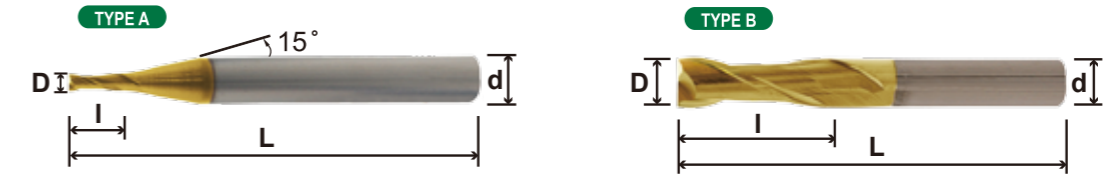

單位：mm (Unit : mm)

產品編號 Model No.	刃徑 D Diameter	刃長 l Flute Length	柄徑 d Shank Diameter	全長 L Overall Length	價格 Price	備註
2 SE 0102TXM	1	3	6	50		
2 SE 0152TXM	1.5	4	6	50		
2 SE 0202TXM	2	6	6	50		
2 SE 0252TXM	2.5	7	6	50		
2 SE 0302TXM	3	8	6	50		
2 SE 0352TXM	3.5	10	6	50		
2 SE 0402TXM	4	11	6	50		
2 SE 0502TXM	5	13	6	50		
2 SE 0602TXM	6	16	6	50		
2 SE 0702TXM	7	18	8	60		
2 SE 0802TXM	8	20	8	60		
2 SE 0902TXM	9	23	10	75		
2 SE 1002TXM	10	30	10	75		
2 SE 1102TXM	11	30	12	75		
2 SE 1202TXM	12	30	12	75		

備註：其他規格，請來電洽詢。

適用材質：

★最適合 ●適合 ▲佳

碳素鋼 Carbon steels	合金鋼 Alloy steel	預硬鋼材	高硬度鋼				不銹鋼 Stainless steels	鈦合金 Titanium alloys	鎳基合金 Nickel Based alloys	銅合金 Copper alloys	鋁合金 Aluminum alloys
		Pre-hardened steels	High-hardened								
★	★	~HRC45	~HRC50	~HRC55	~HRC60	~HRC65	●			●	

**2 MSE2 / SE2 二刃點數鎢鋼立銑刀** TXM OL 35° SHANK h5 HRC 52

MSE2/SE2 (Flat End Mill), 2 Flutes-Micro Decimal Diameter

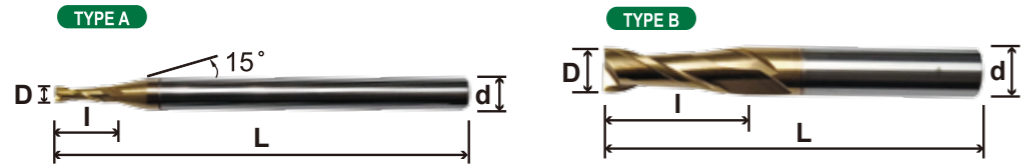

單位 : mm (Unit : mm)

產品編號 Model No.	刃徑 D Diameter	刃長 l Flute Length	柄徑 d Shank Diameter	全長 L Overall Length	價格 Price	備註
2 MSE 0012OL	0.1	0.2	4	50		
2 MSE 0022OL	0.2	0.4	4	50		
2 MSE 0032OL	0.3	0.6	4	50		
2 MSE 0042OL	0.4	0.8	4	50		
2 MSE 0052OL	0.5	1	4	50		
2 MSE 0062OL	0.6	1.2	4	50		
2 MSE 0072OL	0.7	1.4	4	50		
2 MSE 0082OL	0.8	1.6	4	50		
2 MSE 0092OL	0.9	1.8	4	50		
2 MSE 0112TXM	1.1	3	4	50		
2 MSE 0122TXM	1.2	3	4	50		
2 MSE 0132TXM	1.3	3	4	50		
2 MSE 0142TXM	1.4	3	4	50		
2 MSE 0162TXM	1.6	4	4	50		
2 MSE 0172TXM	1.7	4	4	50		
2 MSE 0182TXM	1.8	4	4	50		
2 MSE 0192TXM	1.9	4	4	50		
2 MSE 0212TXM	2.1	6	4	50		
2 MSE 0222TXM	2.2	6	4	50		
2 MSE 0232TXM	2.3	6	4	50		
2 MSE 0242TXM	2.4	6	4	50		
2 MSE 0262TXM	2.6	8	4	50		
2 MSE 0272TXM	2.7	8	4	50		
2 MSE 0282TXM	2.8	8	4	50		
2 MSE 0292TXM	2.9	8	4	50		
2 MSE 0312TXM	3.1	9	4	50		
2 MSE 0322TXM	3.2	9	4	50		
2 MSE 0332TXM	3.3	9	4	50		
2 MSE 0342TXM	3.4	9	4	50		
2 MSE 0362TXM	3.6	10	4	50		
2 MSE 0372TXM	3.7	10	4	50		
2 MSE 0382TXM	3.8	10	4	50		
2 MSE 0392TXM	3.9	10	4	50		
2 SE 0412TXM	4.1	11	6	50		
2 SE 0422TXM	4.2	11	6	50		
2 SE 0432TXM	4.3	11	6	50		
2 SE 0442TXM	4.4	11	6	50		
2 SE 0452TXM	4.5	13	6	50		
2 SE 0462TXM	4.6	13	6	50		
2 SE 0472TXM	4.7	13	6	50		
2 SE 0482TXM	4.8	13	6	50		
2 SE 0492TXM	4.9	13	6	50		

單位 : mm (Unit : mm)

產品編號 Model No.	刃徑 D Diameter	刃長 l Flute Length	柄徑 d Shank Diameter	全長 L Overall Length	價格 Price	備註
2 SE 0512TXM	5.1	14	6	50		
2 SE 0522TXM	5.2	14	6	50		
2 SE 0532TXM	5.3	14	6	50		
2 SE 0542TXM	5.4	14	6	50		
2 SE 0552TXM	5.5	15	6	50		
2 SE 0562TXM	5.6	15	6	50		
2 SE 0572TXM	5.7	15	6	50		
2 SE 0582TXM	5.8	15	6	50		
2 SE 0592TXM	5.9	15	6	50		
2 SE 0612TXM	6.1	17	8	60		
2 SE 0622TXM	6.2	17	8	60		
2 SE 0632TXM	6.3	17	8	60		
2 SE 0642TXM	6.4	17	8	60		
2 SE 0652TXM	6.5	18	8	60		
2 SE 0662TXM	6.6	18	8	60		
2 SE 0672TXM	6.7	18	8	60		
2 SE 0682TXM	6.8	18	8	60		
2 SE 0692TXM	6.9	18	8	60		
2 SE 0712TXM	7.1	19	8	60		
2 SE 0722TXM	7.2	19	8	60		
2 SE 0732TXM	7.3	19	8	60		
2 SE 0742TXM	7.4	19	8	60		
2 SE 0752TXM	7.5	20	8	60		
2 SE 0762TXM	7.6	20	8	60		
2 SE 0772TXM	7.7	20	8	60		
2 SE 0782TXM	7.8	20	8	60		
2 SE 0792TXM	7.9	20	8	60		
2 SE 0812TXM	8.1	21	10	75		
2 SE 0822TXM	8.2	21	10	75		
2 SE 0832TXM	8.3	21	10	75		
2 SE 0842TXM	8.4	21	10	75		
2 SE 0852TXM	8.5	23	10	75		
2 SE 0862TXM	8.6	23	10	75		
2 SE 0872TXM	8.7	23	10	75		
2 SE 0882TXM	8.8	23	10	75		
2 SE 0892TXM	8.9	23	10	75		
2 SE 0912TXM	9.1	25	10	75		
2 SE 0922TXM	9.2	25	10	75		
2 SE 0932TXM	9.3	25	10	75		
2 SE 0942TXM	9.4	25	10	75		
2 SE 0952TXM	9.5	25	10	75		
2 SE 0962TXM	9.6	25	10	75		
2 SE 0972TXM	9.7	25	10	75		
2 SE 0982TXM	9.8	25	10	75		
2 SE 0992TXM	9.9	25	10	75		

# 創新研發 & 波浪銑刀

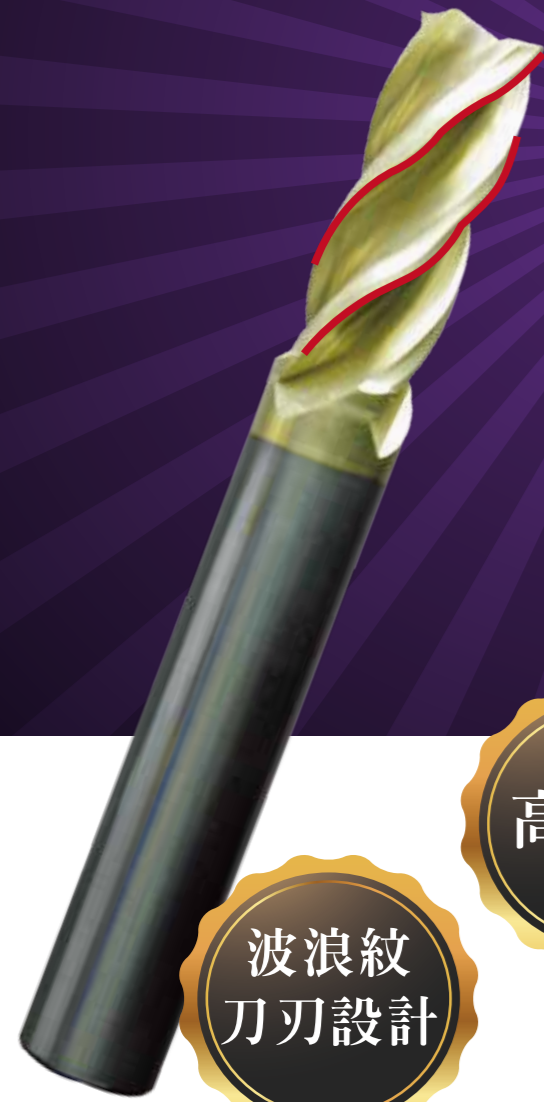

2D GR 35° SHANK h5

## 提升生產效率

特別適用

難切削材 / 不鏽鋼 / 鈦合金 / 合金鋼  
一般鋼材 / 預硬鋼材 / 耐熱合金鋼  
銅合金 / 鋁合金

高品質

高效率

波浪紋  
刀刃設計

抗裂  
韌性



慧德官網



ID:@hdtools



## MSB2 二刃鎢鋼球刀

MSB2 (Ball Nose), 2 Flutes

TXM 30° SHANK h5 HRC >45

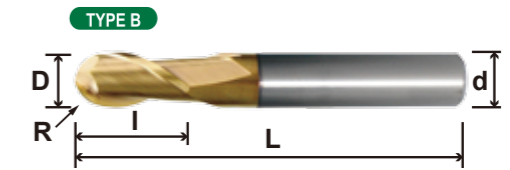
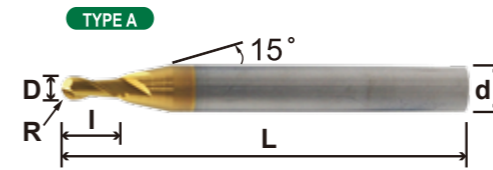

單位: mm (Unit: mm)

產品編號 Model No.	球頭半徑 R Radius	刃徑 D Diameter	刃長 l Flute Length	柄徑 d Shank Diameter	全長 L Overall Length	價格 Price	備註
2 MSB 0102TXM	0.5R	1	2	4	50		
2 SB 0102TXM	0.5R	1	2	6	50		
2 MSB 0152TXM	0.75R	1.5	3	4	50		
2 SB 0152TXM	0.75R	1.5	3	6	50		
2 MSB 0202TXM	1R	2	4	4	50		
2 SB 0202TXM	1R	2	4	6	50		
2 MSB 0252TXM	1.25R	2.5	5	4	50		
2 SB 0252TXM	1.25R	2.5	5	6	50		
2 SSB 0302TXM	1.5R	3	6	3	50		
2 MSB 0302TXM	1.5R	3	6	4	50		
2 SB 0302TXM	1.5R	3	6	6	50		
2 MSB 0352TXM	1.75R	3.5	7	4	50		
2 MSB 0402TXM	2R	4	8	4	50		
2 SB 0402TXM	2R	4	8	6	50		
2 SB 0452TXM	2.25R	4.5	9	6	50		
2 SB 0502TXM	2.5R	5	10	6	50		
2 SB 0602TXM	3R	6	12	6	50		
2 SB 0702TXM	3.5R	7	14	8	60		
2 SB 0802TXM	4R	8	16	8	60		
2 SB 0902TXM	4.5R	9	18	10	75		
2 SB 1002TXM	5R	10	20	10	75		
2 SB 1102TXM	5.5R	11	22	12	75		
2 SB 1202TXM	6R	12	24	12	75		
2 SB 1402TXM	7R	14	28	16	100		
2 SB 1602TXM	8R	16	32	16	100		
2 SB 2002TXM	10R	20	40	20	100		

備註: 其他規格, 請來電洽詢。

**2 SLB2 / MLB2 / LLB2 二刃長柄鎢鋼球刀**



SLB2/MLB2/LLB2 (Ball Nose, Long Shank), 2 Flutes



單位：mm (Unit : mm)

產品編號 Model No.	球頭半徑 R Radius	刃徑 D Diameter	刃長 I Flute Length	柄徑 d Shank Diameter	全長 L Overall Length	價格 Price	備註
2 SLB 0102TXM	0.5R	1	2	4	75		
2 SLB 0102TXM	0.5R	1	2	6	75		
2 MLB 0102TXM	0.5R	1	2	4	100		
2 MLB 0102TXM	0.5R	1	2	6	100		
2 SLB 0152TXM	0.75R	1.5	3	4	75		
2 SLB 0152TXM	0.75R	1.5	3	6	75		
2 MLB 0152TXM	0.75R	1.5	3	4	100		
2 MLB 0152TXM	0.75R	1.5	3	6	100		
2 SLB 0202TXM	1R	2	4	4	75		
2 SLB 0202TXMD6	1R	2	4	6	75		
2 MLB 0202TXM	1R	2	4	4	100		
2 MLB 0202TXMD6	1R	2	4	6	100		
2 SLB 0252TXM	1.25R	2.5	5	4	75		
2 SLB 0252TXMD6	1.25R	2.5	5	6	75		
2 MLB 0252TXM	1.25R	2.5	5	4	100		
2 MLB 0252TXMD6	1.25R	2.5	5	6	100		
2 SLB 0302TXMD3	1.5R	3	6	3	75		
2 SLB 0302TXM	1.5R	3	6	4	75		
2 SLB 0302TXMD6	1.5R	3	6	6	75		
2 MLB 0302TXMD3	1.5R	3	6	3	100		
2 MLB 0302TXM	1.5R	3	6	4	100		
2 MLB 0302TXMD6	1.5R	3	6	6	100		
2 SLB 0402TXM	2R	4	8	4	75		
2 SLB 0402TXMD6	2R	4	8	6	75		
2 MLB 0402TXM	2R	4	8	4	100		
2 MLB 0402TXMD6	2R	4	8	6	100		

單位：mm (Unit : mm)

產品編號 Model No.	球頭半徑 R Radius	刃徑 D Diameter	刃長 I Flute Length	柄徑 d Shank Diameter	全長 L Overall Length	價格 Price	備註
2 SLB 0502TXM	2.5R	5	10	6	75		
2 MLB 0502TXM	2.5R	5	10	6	100		
2 SLB 0602TXM	3R	6	12	6	75		
2 MLB 0602TXM	3R	6	12	6	100		
2 SLB 0802TXM	4R	8	16	8	75		
2 MLB 0802TXM	4R	8	16	8	100		
2 LLB 0802TXM	4R	8	16	8	150		
2 MLB 1002TXM	5R	10	20	10	100		
2 LLB 1002TXM	5R	10	20	10	150		
2 MLB 1202TXM	6R	12	24	12	100		
2 LLB 1202TXM	6R	12	24	12	150		
2 MLB 1602TXM	8R	16	32	16	150		
2 LLB 1602TXM	8R	16	32	16	200		
2 MLB 2002TXM	10R	20	40	20	150		
2 LLB 2002TXM	10R	20	40	20	200		

備註：其他規格，請來電洽詢。

適用材質：

★最適 ●適合 ▲佳

碳素鋼 Carbon steels	合金鋼 Alloy steel	預硬鋼材 Pre-hardened steels	高硬度鋼 High-hardened				不銹鋼 Stainless steels	鈦合金 Titanium alloys	鎳基合金 Nickel Based alloys	銅合金 Copper alloys	鋁合金 Aluminum alloys
		~HRC45	~HRC50	~HRC55	~HRC60	~HRC65					
★	★	●					●			●	

② RTA四刃鎢鋼R角銑刀

RTA (Corner Radius), 4 Flutes



單位：mm (Unit : mm)

產品編號 Model No.	刃徑 D × R角 R Diameter × Corner Radius	刃長 l Flute Length	柄徑 d Shank Diameter	全長 L Overall Length	價格 Price	備註
2 RTA 010024TXM	1 × 0.2R	2	4	50		
2 RTA 015024TXM	1.5 × 0.2R	3	4	50		
2 RTA 015054TXM	1.5 × 0.5R	3	4	50		
2 RTA 020024TXM	2 × 0.2R	4	4	50		
2 RTA 020054TXM	2 × 0.5R	4	4	50		
2 RTA 025024TXM	2.5 × 0.2R	5	4	50		
2 RTA 025054TXM	2.5 × 0.5R	5	4	50		
2 RTA 030024TXMD3	3 × 0.2R	6	3	50		
2 RTA 030024TXM	3 × 0.2R	6	4	50		
2 RTA 030024TXMD6	3 × 0.2R	6	6	50		
2 RTA 030054TXMD3	3 × 0.5R	6	3	50		
2 RTA 030054TXM	3 × 0.5R	6	4	50		
2 RTA 030054TXMD6	3 × 0.5R	6	6	50		
2 RTA 030104TXMD3	3 × 1R	6	3	50		
2 RTA 030104TXM	3 × 1R	6	4	50		
2 RTA 030104TXMD6	3 × 1R	6	6	50		
2 RTA 040024TXM	4 × 0.2R	8	4	50		
2 RTA 040024TXMD6	4 × 0.2R	8	6	50		
2 RTA 040054TXM	4 × 0.5R	8	4	50		
2 RTA 040054TXMD6	4 × 0.5R	8	6	50		
2 RTA 040104TXM	4 × 1R	8	4	50		
2 RTA 040104TXMD6	4 × 1R	8	6	50		
2 RTA 050054TXM	5 × 0.5R	10	6	50		
2 RTA 050104TXM	5 × 1R	10	6	50		
2 RTA 060024TXM	6 × 0.2R	12	6	50		
2 RTA 060054TXM	6 × 0.5R	12	6	50		
2 RTA 060104TXM	6 × 1R	12	6	50		
2 RTA 060154TXM	6 × 1.5R	12	6	50		

單位：mm (Unit : mm)

產品編號 Model No.	刃徑 D × R角 R Diameter × Corner Radius	刃長 l Flute Length	柄徑 d Shank Diameter	全長 L Overall Length	價格 Price	備註
2 RTA 080024TXM	8 × 0.2R	16	8	60		
2 RTA 080054TXM	8 × 0.5R	16	8	60		
2 RTA 080104TXM	8 × 1R	16	8	60		
2 RTA 080204TXM	8 × 2R	16	8	60		
2 RTA 100054TXM	10 × 0.5R	20	10	75		
2 RTA 100104TXM	10 × 1R	20	10	75		
2 RTA 100204TXM	10 × 2R	20	10	75		
2 RTA 120054TXM	12 × 0.5R	24	12	75		
2 RTA 120104TXM	12 × 1R	24	12	75		
2 RTA 120204TXM	12 × 2R	24	12	75		
2 RTA 120304TXM	12 × 3R	24	12	75		

備註：其他規格，請來電洽詢。

適用材質：

★最適合 ●適合 ▲佳

碳素鋼 Carbon steels	合金鋼 Alloy steel	預硬鋼材	高硬度鋼				不銹鋼 Stainless steels	鈦合金 Titanium alloys	鎳基合金 Nickel Based alloys	銅合金 Copper alloys	鋁合金 Aluminum alloys
		Pre-hardened steels	High-hardened								
		~HRC45	~HRC50	~HRC55	~HRC60	~HRC65					
★	★	●					●			●	

**2 SLR4 / MLR4 四刃長柄鎢鋼R角銑刀**

SLR4/MLR4 (Corner Radius, Long Shank), 4 Flutes



單位：mm (Unit : mm)

產品編號 Model No.	刃徑 × R角 D × R Diameter × Corner Radius	刃長 l Flute Length	柄徑 d Shank Diameter	全長 L Overall Length	價格 Price	備註
2 SLR 010024TXM	1 × 0.2R	2	4	75		
2 SLR 010024TXMD6	1 × 0.2R	2	6	75		
2 MLR 010024TXM	1 × 0.2R	2	4	100		
2 MLR 010024TXMD6	1 × 0.2R	2	6	100		
2 SLR 015024TXM	1.5 × 0.2R	3	4	75		
2 SLR 015024TXMD6	1.5 × 0.2R	3	6	75		
2 MLR 015024TXM	1.5 × 0.2R	3	4	100		
2 MLR 015024TXMD6	1.5 × 0.2R	3	6	100		
2 SLR 015054TXM	1.5 × 0.5R	3	4	75		
2 SLR 015054TXMD6	1.5 × 0.5R	3	6	75		
2 MLR 015054TXM	1.5 × 0.5R	3	4	100		
2 MLR 015054TXMD6	1.5 × 0.5R	3	6	100		
2 SLR 020024TXM	2 × 0.2R	4	4	75		
2 SLR 020024TXMD6	2 × 0.2R	4	6	75		
2 MLR 020024TXM	2 × 0.2R	4	4	100		
2 MLR 020024TXMD6	2 × 0.2R	4	6	100		
2 SLR 020054TXM	2 × 0.5R	4	4	75		
2 SLR 020054TXMD6	2 × 0.5R	4	6	75		
2 MLR 020054TXM	2 × 0.5R	4	4	100		
2 MLR 020054TXMD6	2 × 0.5R	4	6	100		
2 SLR 030024TXMD3	3 × 0.2R	6	3	75		
2 SLR 030024TXM	3 × 0.2R	6	4	75		
2 SLR 030024TXMD6	3 × 0.2R	6	6	75		
2 MLR 030024TXMD3	3 × 0.2R	6	3	100		
2 MLR 030024TXM	3 × 0.2R	6	4	100		
2 MLR 030024TXMD6	3 × 0.2R	6	6	100		
2 SLR 030054TXMD3	3 × 0.5R	6	3	75		
2 SLR 030054TXM	3 × 0.5R	6	4	75		
2 SLR 030054TXMD6	3 × 0.5R	6	6	75		
2 MLR 030054TXMD3	3 × 0.5R	6	3	100		
2 MLR 030054TXM	3 × 0.5R	6	4	100		
2 MLR 030054TXMD6	3 × 0.5R	6	6	100		
2 SLR 030104TXMD3	3 × 1 R	6	3	75		
2 SLR 030104TXM	3 × 1 R	6	4	75		
2 SLR 030104TXMD6	3 × 1 R	6	6	75		
2 SLR 030104TXMD3	3 × 1 R	6	3	100		
2 SLR 030104TXM	3 × 1 R	6	4	100		
2 SLR 030104TXMD6	3 × 1 R	6	6	100		

單位：mm (Unit : mm)

產品編號 Model No.	刃徑 × R角 D × R Diameter × Corner Radius	刃長 l Flute Length	柄徑 d Shank Diameter	全長 L Overall Length	價格 Price	備註
2 SLR 040024TXM	4 × 0.2R	8	4	75		
2 SLR 040024TXMD6	4 × 0.2R	8	6	75		
2 MLR 040024TXM	4 × 0.2R	8	4	100		
2 MLR 040024TXMD6	4 × 0.2R	8	6	100		
2 SLR 040054TXM	4 × 0.5R	8	4	75		
2 SLR 040054TXMD6	4 × 0.5R	8	6	75		
2 MLR 040054TXM	4 × 0.5R	8	4	100		
2 MLR 040054TXMD6	4 × 0.5R	8	6	100		
2 SLR 040104TXM	4 × 1R	8	4	75		
2 SLR 040104TXMD6	4 × 1R	8	6	75		
2 MLR 040104TXM	4 × 1R	8	4	100		
2 MLR 040104TXMD6	4 × 1R	8	6	100		
2 SLR 060024TXM	6 × 0.2R	12	6	75		
2 MLR 060024TXM	6 × 0.2R	12	6	100		
2 SLR 060054TXM	6 × 0.5R	12	6	75		
2 MLR 060054TXM	6 × 0.5R	12	6	100		
2 SLR 060104TXM	6 × 1R	12	6	75		
2 MLR 060104TXM	6 × 1R	12	6	100		
2 SLR 080024TXM	8 × 0.2R	16	8	75		
2 MLR 080024TXM	8 × 0.2R	16	8	100		
2 SLR 080054TXM	8 × 0.5R	16	8	75		
2 MLR 080054TXM	8 × 0.5R	16	8	100		
2 SLR 080104TXM	8 × 1R	16	8	75		
2 MLR 080104TXM	8 × 1R	16	8	100		
2 SLR 080204TXM	8 × 2R	16	8	75		
2 MLR 080204TXM	8 × 2R	16	8	100		
2 MLR 100054TXM	10 × 0.5R	20	10	100		
2 MLR 100104TXM	10 × 1R	20	10	100		
2 MLR 100204TXM	10 × 2R	20	10	100		
2 MLR 120054TXM	12 × 0.5R	24	12	100		
2 MLR 120104TXM	12 × 1R	24	12	100		
2 MLR 120204TXM	12 × 2R	24	12	100		
2 MLR 120304TXM	12 × 3R	24	12	100		

備註：其他規格，請來電洽詢。

適用材質：

★最適 ●適合 ▲佳

碳素鋼 Carbon steels	合金鋼 Alloy steel	預硬鋼材 Pre-hardened steels	高硬度鋼 High-hardened					不銹鋼 Stainless steels	鈦合金 Titanium alloys	鎳基合金 Nickel Based alloys	銅合金 Copper alloys	鋁合金 Aluminum alloys
			~HRC45	~HRC50	~HRC55	~HRC60	~HRC65					
★	★	●						●			●	

**5 MHD 四刃重切削鎢鋼立銑刀**

MHD (Heavy Cutting Operation Type), 4 Flutes

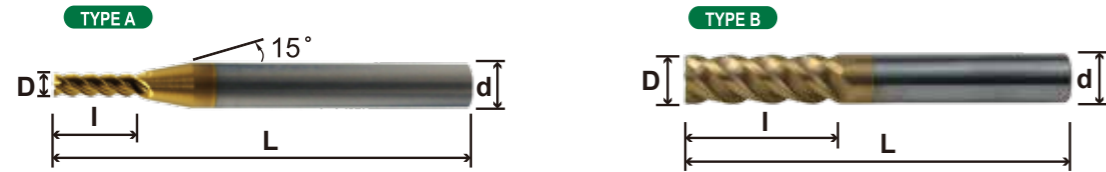

單位：mm (Unit : mm)

產品編號 Model No.	刃徑 D Diameter	刃長 l Flute Length	柄徑 d Shank Diameter	全長 L Overall Length	價格 Price	備註
5 MSE 0104TX	1	3	4	50		
5 SE 0104TX	1	3	6	50		
5 MSE 0154TX	1.5	4	4	50		
5 SE 0154TX	1.5	4	6	50		
5 MSE 0204TX	2	6	4	50		
5 SE 0204TX	2	6	6	50		
5 MSE 0254TX	2.5	8	4	50		
5 SE 0254TX	2.5	8	6	50		
5 MHD 0304TXD3	3	8	3	50		
5 MHD 0304TX	3	8	4	50		
5 MHD 0304TXD6	3	8	6	50		
5 MHD 0354TX	3.5	10	4	50		
5 MHD 0354TXD6	3.5	10	6	50		
5 MHD 0404TX	4	11	4	50		
5 MHD 0404TXD6	4	11	6	50		
5 MHD 0504TX	5	13	6	50		
5 MHD 0604TX	6	16	6	50		
5 MHD 0704TX	7	18	8	60		
5 MHD 0804TX	8	20	8	60		
5 MHD 0904TX	9	25	10	75		
5 MHD 1004TX	10	30	10	75		
5 MHD 1104TX	11	28	12	75		
5 MHD 1204TX	12	30	12	75		
5 MHD 1304TX	13	40	16	100		
5 MHD 1404TX	14	40	16	100		
5 MHD 1504TX	15	45	16	100		
5 MHD 1604TX	16	50	16	100		
5 MHD 1804TX	18	50	20	100		
5 MHD 2004TX	20	50	20	100		

備註：其他規格，請來電洽詢。

適用材質：★最適合 ●適合 ▲佳

碳素鋼 Carbon steels	合金鋼 Alloy steel	預硬鋼材	高硬度鋼					不銹鋼 Stainless steels	鈦合金 Titanium alloys	鎳基合金 Nickel Based alloys	銅合金 Copper alloys	鋁合金 Aluminum alloys
		Pre-hardened steels ~HRC45	~HRC50	~HRC55	~HRC60	~HRC65						
●	★	★	★	●							●	

**5 MSE2 小徑鎢鋼立銑刀**

MSE2 (Flat End Mill), 2 Flutes Decimal Diameter

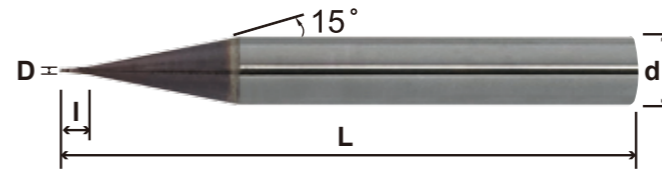

單位：mm (Unit : mm)

產品編號 Model No.	刃徑 D Diameter	刃長 l Flute Length	柄徑 d Shank Diameter	全長 L Overall Length	價格 Price	備註
5 MSE 0012OL	0.1	0.2	4	50		
5 MSE 0022OL	0.2	0.4	4	50		
5 MSE 0032OL	0.3	0.6	4	50		
5 MSE 0042OL	0.4	0.8	4	50		
5 MSE 0052OL	0.5	1.0	4	50		
5 MSE 0062OL	0.6	1.2	4	50		
5 MSE 0072OL	0.7	1.4	4	50		
5 MSE 0082OL	0.8	1.6	4	50		
5 MSE 0092OL	0.9	1.8	4	50		

備註：其他規格，請來電洽詢。

適用材質：

★最適合 ●適合 ▲佳

碳素鋼 Carbon steels	合金鋼 Alloy steel	預硬鋼材	高硬度鋼					不銹鋼 Stainless steels	鈦合金 Titanium alloys	鎳基合金 Nickel Based alloys	銅合金 Copper alloys	鋁合金 Aluminum alloys
		Pre-hardened steels ~HRC45	~HRC50	~HRC55	~HRC60	~HRC65						
●	★	★	★	●							●	▲



**5 SLE4 / MLE4 / LLE4 四刃長柄鎢鋼立銑刀** TX   

SLE4/MLE4/LLE4 (Long Shank, Regular Length), 4 Flutes

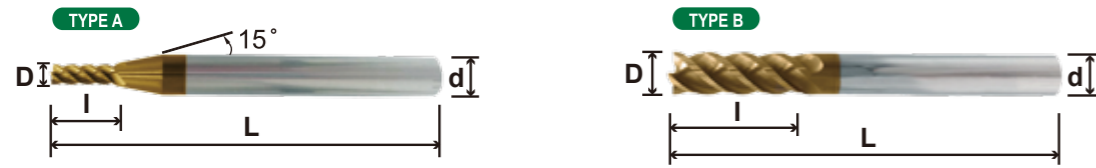

單位：mm (Unit : mm)

產品編號 Model No.	刃徑 D Diameter	刃長 l Flute Length	柄徑 d Shank Diameter	全長 L Overall Length	價格 Price	備註
5 SLE 0104TXD6	1	2.5	6	75		
5 MLE 0104TXD6	1	2.5	6	100		
5 SLE 0154TXD6	1.5	4	6	75		
5 MLE 0154TXD6	1.5	4	6	100		
5 SLE 0204TXD6	2	6	6	75		
5 MLE 0204TXD6	2	6	6	100		
5 SLE 0254TXD6	2.5	7	6	75		
5 MLE 0254TXD6	2.5	7	6	100		
5 SLE 0304TXD3	3	8	3	75		
5 SLE 0304TX	3	8	4	75		
5 SLE 0304TXD6	3	8	6	75		
5 MLE 0304TXD3	3	8	3	100		
5 MLE 0304TX	3	8	4	100		
5 MLE 0304TXD6	3	8	6	100		
5 SLE 0404TX	4	11	4	75		
5 SLE 0404TXD6	4	11	6	75		
5 MLE 0404TX	4	11	4	100		
5 MLE 0404TXD6	4	11	6	100		
5 SLE 0504TX	5	13	6	75		
5 MLE 0504TX	5	13	6	100		
5 SLE 0604TX	6	16	6	75		
5 MLE 0604TX	6	16	6	100		

單位：mm (Unit : mm)

產品編號 Model No.	刃徑 D Diameter	刃長 l Flute Length	柄徑 d Shank Diameter	全長 L Overall Length	價格 Price	備註
5 MLE 0704TX	7	18	8	100		
5 SLE 0804TX	8	20	8	75		
5 MLE 0804TX	8	20	8	100		
5 LLE 0804TX	8	20	8	150		
5 MLE 0904TX	9	23	10	100		
5 MLE 1004TX	10	30	10	100		
5 LLE 1004TX	10	30	10	150		
5 MLE 1204TX	12	30	12	100		
5 LLE 1204TX	12	30	12	150		
5 MLE 1604TX	16	50	16	150		
5 LLE 1604TX	16	50	16	200		
5 MLE 2004TX	20	50	20	150		
5 LLE 2004TX	20	50	20	200		

備註：其他規格，請來電洽詢。

適用材質：

★最適合 ●適合 ▲佳

碳素鋼 Carbon steels	合金鋼 Alloy steel	預硬鋼材	高硬度鋼			不銹鋼 Stainless steels	鈦合金 Titanium alloys	鎳基合金 Nickel Based alloys	銅合金 Copper alloys	鋁合金 Aluminum alloys
		Pre-hardened steels	High-hardened							
		~HRC45	~HRC50	~HRC55	~HRC60	~HRC65				
●	★	★	★	●					●	

**5 LET4 四刃長刃鎢鋼立銑刀**

LET4 (Long Flute Length End Mill), 4 Flutes

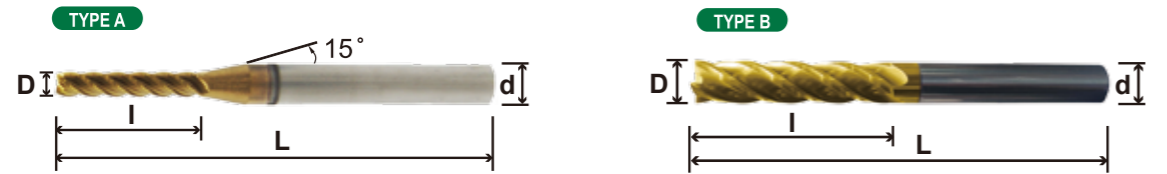

單位: mm (Unit: mm)

產品編號 Model No.	刃徑 D Diameter	刃長 l Flute Length	柄徑 d Shank Diameter	全長 L Overall Length	價格 Price	備註
5 LET 0104TX	1	5	4	50		
5 LET 0154TX	1.5	8	4	50		
5 LET 0204TX	2	10	4	50		
5 LET 0254TX	2.5	13	4	50		
5 LET 0304TX	3	15	6	50		
5 LET 0404TX	4	20	6	75		
5 LET 0504TX	5	25	6	75		
5 LET 0604TX	6	30	6	75		
5 LET 0704TX	7	35	8	100		
5 LET 0804TX	8	40	8	100		
5 LET 0904TX	9	45	10	100		
5 LET 1004TX	10	50	10	100		
5 LET 1204TX	12	50	12	100		
5 LET 1604TX	16	80	16	150		
5 LET 2004TX	20	80	20	150		

備註: 其他規格, 請來電洽詢。

適用材質:

★最適合 ●適合 ▲佳

碳素鋼 Carbon steels	合金鋼 Alloy steel	預硬鋼材 Pre-hardened steels		高硬度鋼 High-hardened				不銹鋼 Stainless steels	鈦合金 Titanium alloys	鎳基合金 Nickel Based alloys	銅合金 Copper alloys	鋁合金 Aluminum alloys
		~HRC45	~HRC50	~HRC55	~HRC60	~HRC65						
●	★	★	★	●							●	

**HD.** 氣動研磨工具

Hwe Der & Ho Dung



編號  
**Air-6302**

轉速/Speed	65,000 rpm
尺寸/Dimension(mm)	Max $\phi$ 22x140L
重量/Weight	98g
筒夾/Collet Chuck	$\phi$ 3.0mm、 $\phi$ 1/8"、 $\phi$ 2.34" mm

西德軸承/日本葉片/不鏽鋼主軸



編號  
**Air-6345**

轉速/Speed	23,500 rpm
尺寸/Dimension(mm)	Max $\phi$ 16.5x136L
重量/Weight	200g
筒夾/Collet Chuck	M7 screw shaft



編號  
**TL-A30**  
渦輪式

往復行程/Stroke	0.3mm
往復頻率/Frequency	30,000 strokes/min
空氣消耗量/Air Consumption	0.08m <sup>3</sup> /min
輸出壓力/Pressure Recommended	90 psi
尺寸/Dimension(mm)	Max. $\phi$ 28x185L
重量/Weight	220g



編號  
**TL-A70**  
渦輪式

往復行程/Stroke	0.7mm
往復頻率/Frequency	30,000 strokes/min
空氣消耗量/Air Consumption	0.08m <sup>3</sup> /min
輸出壓力/Pressure Recommended	90 psi
尺寸/Dimension(mm)	Max. $\phi$ 28x205L
重量/Weight	220g

**5 MSB2 / SB2 二刃鎢鋼球刀**

MSB2 (Ball Nose), 2 Flutes

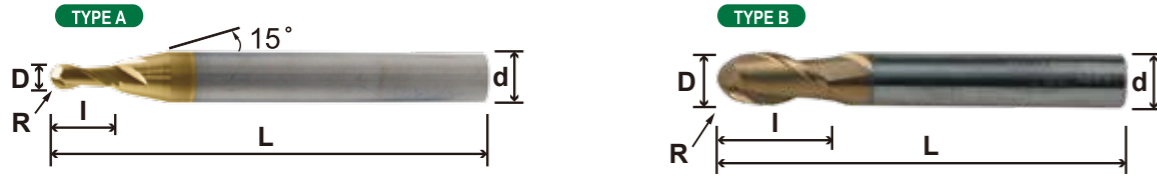

單位：mm (Unit : mm)

產品編號 Model No.	球頭半徑 R Radius	刃徑 D Diameter	刃長 l Flute Length	柄徑 d Shank Diameter	全長 L Overall Length	價格 Price	備註
5 MSB 0102TX	0.5R	1	2	4	50		
5 SB 0102TX	0.5R	1	2	6	50		
5 MSB 0152TX	0.75R	1.5	3	4	50		
5 SB 0152TX	0.75R	1.5	3	6	50		
5 MSB 0202TX	1R	2	4	4	50		
5 SB 0202TX	1R	2	4	6	50		
5 MSB 0252TX	1.25R	2.5	5	4	50		
5 SB 0252TX	1.25R	2.5	5	6	50		
5 SSB 0302TX	1.5R	3	6	3	50		
5 MSB 0302TX	1.5R	3	6	4	50		
5 SB 0302TX	1.5R	3	6	6	50		
5 MSB 0352TX	1.75R	3.5	7	4	50		
5 MSB 0402TX	2R	4	8	4	50		
5 SB 0402TX	2R	4	8	6	50		
5 SB 0452TX	2.25R	4.5	9	6	50		
5 SB 0502TX	2.5R	5	10	6	50		
5 SB 0602TX	3R	6	12	6	50		
5 SB 0702TX	3.5R	7	14	8	60		
5 SB 0802TX	4R	8	16	8	60		
5 SB 0902TX	4.5R	9	18	10	75		
5 SB 1002TX	5R	10	20	10	75		
5 SB 1102TX	5.5R	11	22	12	75		
5 SB 1202TX	6R	12	24	12	75		
5 SB 1602TX	8R	16	32	16	100		
5 SB 2002TX	10R	20	40	20	100		

備註：其他規格，請來電洽詢。

適用材質：

★最適合 ●適合 ▲佳

碳素鋼 Carbon steels	合金鋼 Alloy steel	預硬鋼材 Pre-hardened steels		高硬度鋼 High-hardened					不銹鋼 Stainless steels	鈦合金 Titanium alloys	鎳基合金 Nickel Based alloys	銅合金 Copper alloys	鋁合金 Aluminum alloys
		~HRC45	~HRC50	~HRC55	~HRC60	~HRC65							
●	★	★	★	●								●	

**5 MSB 小徑鎢鋼球刀**

MSB (Ball Nose), 2 Flutes-Decimal Diameter

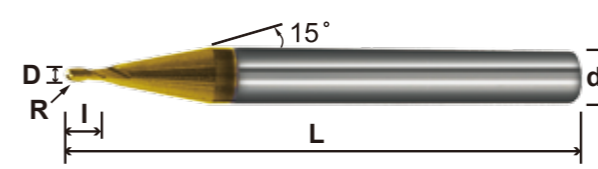

單位：mm (Unit : mm)

產品編號 Model No.	球頭半徑 R Radius	刃徑 D Diameter	刃長 l Flute Length	柄徑 d Shank Diameter	全長 L Overall Length	價格 Price	備註
5 MSB 0022OL	0.1R	0.2	0.4	4	50		
5 MSB 0032OL	0.15R	0.3	0.6	4	50		
5 MSB 0042OL	0.2R	0.4	0.8	4	50		
5 MSB 0052OL	0.25R	0.5	1	4	50		
5 MSB 0062OL	0.3R	0.6	1.2	4	50		
5 MSB 0072OL	0.35R	0.7	1.4	4	50		
5 MSB 0082OL	0.4R	0.8	1.6	4	50		
5 MSB 0092OL	0.45R	0.9	1.8	4	50		
5 MSB 0112TX	0.55R	1.1	2.2	4	50		
5 MSB 0122TX	0.6R	1.2	2.4	4	50		
5 MSB 0132TX	0.65R	1.3	2.6	4	50		
5 MSB 0142TX	0.7R	1.4	2.8	4	50		
5 MSB 0162TX	0.8R	1.6	3.2	4	50		
5 MSB 0172TX	0.85R	1.7	3.4	4	50		
5 MSB 0182TX	0.9R	1.8	3.6	4	50		
5 MSB 0192TX	0.95R	1.9	3.8	4	50		
5 MSB 0212TX	1.05R	2.1	4.2	4	50		
5 MSB 0222TX	1.1R	2.2	4.4	4	50		
5 MSB 0232TX	1.15R	2.3	4.6	4	50		
5 MSB 0242TX	1.2R	2.4	4.8	4	50		
5 MSB 0262TX	1.3R	2.6	5.2	4	50		
5 MSB 0272TX	1.35R	2.7	5.4	4	50		
5 MSB 0282TX	1.4R	2.8	5.5	4	50		
5 MSB 0292TX	1.45R	2.9	5.8	4	50		

備註：其他規格，請來電洽詢。

適用材質：

★最適合 ●適合 ▲佳

碳素鋼 Carbon steels	合金鋼 Alloy steel	預硬鋼材 Pre-hardened steels		高硬度鋼 High-hardened					不銹鋼 Stainless steels	鈦合金 Titanium alloys	鎳基合金 Nickel Based alloys	銅合金 Copper alloys	鋁合金 Aluminum alloys
		~HRC45	~HRC50	~HRC55	~HRC60	~HRC65							
●	★	★	★	●								●	

**5 SLB2 / MLB2 / LLB2 二刃長柄鎢鋼球刀**



SLB2/MLB2/LLB2 (Ball Nose, Long Shank), 2 Flutes



單位：mm (Unit : mm)

產品編號 Model No.	球頭半徑 R Radius	刃徑 D Diameter	刃長 l Flute Length	柄徑 d Shank Diameter	全長 L Overall Length	價格 Price	備註
5 SLB 0102TX	0.5R	1	2	4	75		
5 SLB 0102TXD6	0.5R	1	2	6	75		
5 MLB 0102TX	0.5R	1	2	4	100		
5 MLB 0102TXD6	0.5R	1	2	6	100		
5 SLB 0152TX	0.75R	1.5	3	4	75		
5 SLB 0152TXD6	0.75R	1.5	3	6	75		
5 MLB 0152TX	0.75R	1.5	3	4	100		
5 MLB 0152TXD6	0.75R	1.5	3	6	100		
5 SLB 0202TX	1R	2	4	4	75		
5 SLB 0202TXD6	1R	2	4	6	75		
5 MLB 0202TX	1R	2	4	4	100		
5 MLB 0202TXD6	1R	2	4	6	100		
5 SLB 0252TX	1.25R	2.5	5	4	75		
5 SLB 0252TXD6	1.25R	2.5	5	6	75		
5 MLB 0252TX	1.25R	2.5	5	4	100		
5 MLB 0252TXD6	1.25R	2.5	5	6	100		
5 SLB 0302TXD3	1.5R	3	6	3	75		
5 SLB 0302TX	1.5R	3	6	4	75		
5 SLB 0302TXD6	1.5R	3	6	6	75		
5 MLB 0302TXD3	1.5R	3	6	3	100		
5 MLB 0302TX	1.5R	3	6	4	100		
5 MLB 0302TXD6	1.5R	3	6	6	100		
5 SLB 0402TX	2R	4	8	4	75		
5 SLB 0402TXD6	2R	4	8	6	75		
5 MLB 0402TX	2R	4	8	4	100		
5 MLB 0402TXD6	2R	4	8	6	100		

單位：mm (Unit : mm)

產品編號 Model No.	球頭半徑 R Radius	刃徑 D Diameter	刃長 l Flute Length	柄徑 d Shank Diameter	全長 L Overall Length	價格 Price	備註
5 SLB 0502TX	2.5R	5	10	6	75		
5 MLB 0502TX	2.5R	5	10	6	100		
5 SLB 0602TX	3R	6	12	6	75		
5 MLB 0602TX	3R	6	12	6	100		
5 SLB 0802TX	4R	8	16	8	75		
5 MLB 0802TX	4R	8	16	8	100		
5 LLB 0802TX	4R	8	16	8	150		
5 MLB 1002TX	5R	10	20	10	100		
5 LLB 1002TX	5R	10	20	10	150		
5 MLB 1202TX	6R	12	24	12	100		
5 LLB 1202TX	6R	12	24	12	150		
5 MLB 1602TX	8R	16	32	16	150		
5 LLB 1602TX	8R	16	32	16	200		
5 MLB 2002TX	10R	20	40	20	150		
5 LLB 2002TX	10R	20	40	20	200		

備註：其他規格，請來電洽詢。

適用材質：

★最適 ●適合 ▲佳

碳素鋼 Carbon steels	合金鋼 Alloy steel	預硬鋼材 Pre-hardened steels		高硬度鋼 High-hardened			不銹鋼 Stainless steels	鈦合金 Titanium alloys	鎳基合金 Nickel Based alloys	銅合金 Copper alloys	鋁合金 Aluminum alloys
		~HRC45	~HRC50	~HRC55	~HRC60	~HRC65					
●	★	★	★	●						●	

5 RTA 四刃鎢鋼R角銑刀

RTA (Corner Radius), 4 Flutes



單位：mm (Unit : mm)

產品編號 Model No.	刃徑 D × R角 R Diameter × Corner Radius	刃長 l Flute Length	柄徑 d Shank Diameter	全長 L Overall Length	價格 Price	備註
5 RTA 010014TX	1 × 0.1R	2	4	50		
5 RTA 010024TX	1 × 0.2R	2	4	50		
5 RTA 015024TX	1.5 × 0.2R	3	4	50		
5 RTA 015054TX	1.5 × 0.5R	3	4	50		
5 RTA 020014TX	2 × 0.1R	4	4	50		
5 RTA 020024TX	2 × 0.2R	4	4	50		
5 RTA 020054TX	2 × 0.5R	4	4	50		
5 RTA 025024TX	2.5 × 0.2R	5	4	50		
5 RTA 025054TX	2.5 × 0.5R	5	4	50		
5 RTA 030014TX	3 × 0.1R	6	4	50		
5 RTA 030024TXD3	3 × 0.2R	6	3	50		
5 RTA 030024TX	3 × 0.2R	6	4	50		
5 RTA 030024TXD6	3 × 0.2R	6	6	50		
5 RTA 030054TXD3	3 × 0.5R	6	3	50		
5 RTA 030054TX	3 × 0.5R	6	4	50		
5 RTA 030054TXD6	3 × 0.5R	6	6	50		
5 RTA 030104TXD3	3 × 1R	6	3	50		
5 RTA 030104TX	3 × 1R	6	4	50		
5 RTA 030104TXD6	3 × 1R	6	6	50		
5 RTA 040014TX	4 × 0.1R	8	4	50		
5 RTA 040024TX	4 × 0.2R	8	4	50		
5 RTA 040024TXD6	4 × 0.2R	8	6	50		
5 RTA 040054TX	4 × 0.5R	8	4	50		
5 RTA 040054TXD6	4 × 0.5R	8	6	50		
5 RTA 040104TX	4 × 1R	8	4	50		
5 RTA 040104TXD6	4 × 1R	8	6	50		
5 RTA 050054TX	5 × 0.5R	10	6	50		
5 RTA 050104TX	5 × 1R	10	6	50		
5 RTA 060024TX	6 × 0.2R	12	6	50		
5 RTA 060054TX	6 × 0.5R	12	6	50		
5 RTA 060104TX	6 × 1R	12	6	50		
5 RTA 060154TX	6 × 1.5R	12	6	50		

單位：mm (Unit : mm)

產品編號 Model No.	刃徑 D × R角 R Diameter × Corner Radius	刃長 l Flute Length	柄徑 d Shank Diameter	全長 L Overall Length	價格 Price	備註
5 RTA 080024TX	8 × 0.2R	16	8	60		
5 RTA 080054TX	8 × 0.5R	16	8	60		
5 RTA 080104TX	8 × 1R	16	8	60		
5 RTA 080204TX	8 × 2R	16	8	60		
5 RTA 100054TX	10 × 0.5R	20	10	75		
5 RTA 100104TX	10 × 1R	20	10	75		
5 RTA 100204TX	10 × 2R	20	10	75		
5 RTA 120054TX	12 × 0.5R	24	12	75		
5 RTA 120104TX	12 × 1R	24	12	75		
5 RTA 120204TX	12 × 2R	24	12	75		
5 RTA 120304TX	12 × 3R	24	12	75		

備註：其他規格，請來電洽詢。

適用材質：

★最適合 ●適合 ▲佳

碳素鋼 Carbon steels	合金鋼 Alloy steel	預硬鋼材	高硬度鋼				不銹鋼 Stainless steels	鈦合金 Titanium alloys	鎳基合金 Nickel Based alloys	銅合金 Copper alloys	鋁合金 Aluminum alloys
		Pre-hardened steels	High-hardened								
		~HRC45	~HRC50	~HRC55	~HRC60	~HRC65					
●	★	★	★	●						●	

5 SLR4 / MLR4 四刃長柄鎢鋼R角銑刀



SLR4/MLR4 (Corner Radius, Long Shank), 4 Flutes



單位：mm (Unit : mm)

產品編號 Model No.	刃徑 D × R角 Diameter × Corner Radius	刃長 l Flute Length	柄徑 d Shank Diameter	全長 L Overall Length	價格 Price	備註
5 SLR 010024TX	1 × 0.2R	2	4	75		
5 SLR 010024TXD6	1 × 0.2R	2	6	75		
5 MLR 010024TX	1 × 0.2R	2	4	100		
5 MLR 010024TXD6	1 × 0.2R	2	6	100		
5 SLR 015024TX	1.5 × 0.2R	3	4	75		
5 SLR 015024TXD6	1.5 × 0.2R	3	6	75		
5 MLR 015024TX	1.5 × 0.2R	3	4	100		
5 MLR 015024TXD6	1.5 × 0.2R	3	6	100		
5 SLR 015054TX	1.5 × 0.5R	3	4	75		
5 SLR 015054TXD6	1.5 × 0.5R	3	6	75		
5 MLR 015054TX	1.5 × 0.5R	3	4	100		
5 MLR 015054TXD6	1.5 × 0.5R	3	6	100		
5 SLR 020024TX	2 × 0.2R	4	4	75		
5 SLR 020024TXD6	2 × 0.2R	4	6	75		
5 MLR 020024TX	2 × 0.2R	4	4	100		
5 MLR 020024TXD6	2 × 0.2R	4	6	100		
5 SLR 020054TX	2 × 0.5R	4	4	75		
5 SLR 020054TXD6	2 × 0.5R	4	6	75		
5 MLR 020054TX	2 × 0.5R	4	4	100		
5 MLR 020054TXD6	2 × 0.5R	4	6	100		
5 SLR 030024TXD3	3 × 0.2R	6	3	75		
5 SLR 030024TX	3 × 0.2R	6	4	75		
5 SLR 030024TXD6	3 × 0.2R	6	6	75		
5 MLR 030024TXD3	3 × 0.2R	6	3	100		
5 MLR 030024TX	3 × 0.2R	6	4	100		
5 MLR 030024TXD6	3 × 0.2R	6	6	100		
5 SLR 030054TXD3	3 × 0.5R	6	3	75		
5 SLR 030054TX	3 × 0.5R	6	4	75		
5 SLR 030054TXD6	3 × 0.5R	6	6	75		
5 MLR 030054TXD3	3 × 0.5R	6	3	100		
5 MLR 030054TX	3 × 0.5R	6	4	100		
5 MLR 030054TXD6	3 × 0.5R	6	6	100		
5 SLR 030104TXD3	3 × 1R	6	3	75		
5 SLR 030104TX	3 × 1R	6	4	75		
5 SLR 030104TXD6	3 × 1R	6	6	75		
5 SLR 030104TXD3	3 × 1R	6	3	100		
5 SLR 030104TX	3 × 1R	6	4	100		
5 SLR 030104TXD6	3 × 1R	6	6	100		

單位：mm (Unit : mm)

產品編號 Model No.	刃徑 D × R角 Diameter × Corner Radius	刃長 l Flute Length	柄徑 d Shank Diameter	全長 L Overall Length	價格 Price	備註
5 SLR 040024TX	4 × 0.2R	8	4	75		
5 SLR 040024TXD6	4 × 0.2R	8	6	75		
5 MLR 040024TX	4 × 0.2R	8	4	100		
5 MLR 040024TXD6	4 × 0.2R	8	6	100		
5 SLR 040054TX	4 × 0.5R	8	4	75		
5 SLR 040054TXD6	4 × 0.5R	8	6	75		
5 MLR 040054TX	4 × 0.5R	8	4	100		
5 MLR 040054TXD6	4 × 0.5R	8	6	100		
5 SLR 040104TX	4 × 1R	8	4	75		
5 SLR 040104TXD6	4 × 1R	8	6	75		
5 MLR 040104TX	4 × 1R	8	4	100		
5 MLR 040104TXD6	4 × 1R	8	6	100		
5 SLR 060024TX	6 × 0.2R	12	6	75		
5 MLR 060024TX	6 × 0.2R	12	6	100		
5 SLR 060054TX	6 × 0.5R	12	6	75		
5 MLR 060054TX	6 × 0.5R	12	6	100		
5 SLR 060104TX	6 × 1R	12	6	75		
5 MLR 060104TX	6 × 1R	12	6	100		
5 SLR 080024TX	8 × 0.2R	16	8	75		
5 MLR 080024TX	8 × 0.2R	16	8	100		
5 SLR 080054TX	8 × 0.5R	16	8	75		
5 MLR 080054TX	8 × 0.5R	16	8	100		
5 SLR 080104TX	8 × 1R	16	8	75		
5 MLR 080104TX	8 × 1R	16	8	100		
5 SLR 080204TX	8 × 2R	16	8	75		
5 MLR 080204TX	8 × 2R	16	8	100		
5 MLR 100054TX	10 × 0.5R	20	10	100		
5 MLR 100104TX	10 × 1R	20	10	100		
5 MLR 100204TX	10 × 2R	20	10	100		
5 MLR 120054TX	12 × 0.5R	24	12	100		
5 MLR 120104TX	12 × 1R	24	12	100		
5 MLR 120204TX	12 × 2R	24	12	100		
5 MLR 120304TX	12 × 3R	24	12	100		

備註：其他規格，請來電洽詢。

適用材質：

★最適合 ●適合 ▲佳

碳素鋼 Carbon steels	合金鋼 Alloy steel	預硬鋼材 Pre-hardened steels	高硬度鋼 High-hardened					不銹鋼 Stainless steels	鈦合金 Titanium alloys	鎳基合金 Nickel Based alloys	銅合金 Copper alloys	鋁合金 Aluminum alloys
		~HRC45	~HRC50	~HRC55	~HRC60	~HRC65						
●	★	★	★	●						●		

**5 LNT 二刃深溝加工用鎢鋼立銑刀**

LNT (For Deep Processing, Long Neck), 2 Flutes

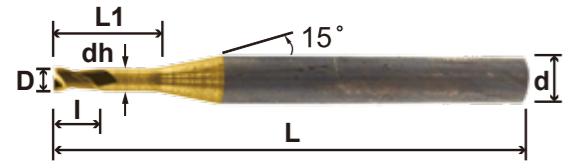

單位 : mm (Unit : mm)

產品編號 Model No.	刃徑 D Diameter	刃長 l Flute Length	有效長 L1 Effective Length	頸徑 dh Neck dia	柄徑 d Shank Diameter	全長 L Overall Length	價格 Price	備註
5 LNT 020102OL	0.2	0.2	1	0.17	4	50		
5 LNT 020152OL	0.2	0.2	1.5	0.17	4	50		
5 LNT 020202OL	0.2	0.2	2	0.17	4	50		
5 LNT 030152OL	0.3	0.3	1.5	0.26	4	50		
5 LNT 030202OL	0.3	0.3	2	0.26	4	50		
5 LNT 030302OL	0.3	0.3	3	0.26	4	50		
5 LNT 040202OL	0.4	0.4	2	0.35	4	50		
5 LNT 040302OL	0.4	0.4	3	0.35	4	50		
5 LNT 040402OL	0.4	0.4	4	0.35	4	50		
5 LNT 040502OL	0.4	0.4	5	0.35	4	50		
5 LNT 050302OL	0.5	0.5	3	0.45	4	50		
5 LNT 050402OL	0.5	0.5	4	0.45	4	50		
5 LNT 050602OL	0.5	0.5	6	0.45	4	50		
5 LNT 060302OL	0.6	0.6	3	0.55	4	50		
5 LNT 060402OL	0.6	0.6	4	0.55	4	50		
5 LNT 060602OL	0.6	0.6	6	0.55	4	50		
5 LNT 060802OL	0.6	0.6	8	0.55	4	50		
5 LNT 080402OL	0.8	0.8	4	0.75	4	50		
5 LNT 080602OL	0.8	0.8	6	0.75	4	50		
5 LNT 080802OL	0.8	0.8	8	0.75	4	50		
5 LNT 081002OL	0.8	0.8	10	0.75	4	50		
5 LNT 100602TX	1	1	6	0.95	4	50		
5 LNT 100802TX	1	1	8	0.95	4	50		
5 LNT 101002TX	1	1	10	0.95	4	50		
5 LNT 101202TX	1	1	12	0.95	4	50		
5 LNT 120602TX	1.2	1.2	6	1.15	4	50		
5 LNT 120802TX	1.2	1.2	8	1.15	4	50		
5 LNT 121002TX	1.2	1.2	10	1.15	4	50		
5 LNT 121202TX	1.2	1.2	12	1.15	4	50		
5 LNT 121602TX	1.2	1.2	16	1.15	4	50		
5 LNT 150802TX	1.5	1.5	8	1.45	4	50		
5 LNT 151002TX	1.5	1.5	10	1.45	4	50		
5 LNT 151202TX	1.5	1.5	12	1.45	4	50		
5 LNT 151602TX	1.5	1.5	16	1.45	4	50		
5 LNT 201002TX	2	2	10	1.95	4	50		
5 LNT 201202TX	2	2	12	1.95	4	50		
5 LNT 201602TX	2	2	16	1.95	4	50		
5 LNT 202002TX	2	2	20	1.95	4	50		

**5 LNB 二刃深溝加工用鎢鋼球刀**

LNB (Ball Nose For Deep Processing, Long Neck), 2 Flutes

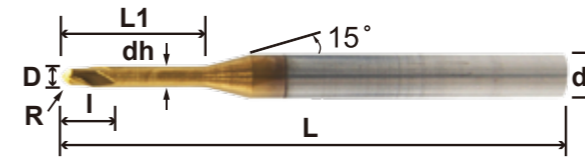

單位 : mm (Unit : mm)

產品編號 Model No.	球頭半徑 R Radius	刃徑 D Diameter	刃長 l Flute Length	有效長 L1 Effective Length	頸徑 dh Neck dia	柄徑 d Shank Diameter	全長 L Overall Length	價格 Price	備註
5 LNB 020102OL	0.1R	0.2	0.2	1	0.17	4	50		
5 LNB 020152OL	0.1R	0.2	0.2	1.5	0.17	4	50		
5 LNB 020202OL	0.1R	0.2	0.2	2	0.17	4	50		
5 LNB 030152OL	0.15R	0.3	0.3	1.5	0.26	4	50		
5 LNB 030202OL	0.15R	0.3	0.3	2	0.26	4	50		
5 LNB 030302OL	0.15R	0.3	0.3	3	0.26	4	50		
5 LNB 040202OL	0.2R	0.4	0.4	2	0.35	4	50		
5 LNB 040302OL	0.2R	0.4	0.4	3	0.35	4	50		
5 LNB 040402OL	0.2R	0.4	0.4	4	0.35	4	50		
5 LNB 040502OL	0.2R	0.4	0.4	5	0.35	4	50		
5 LNB 050302OL	0.25R	0.5	0.5	3	0.45	4	50		
5 LNB 050402OL	0.25R	0.5	0.5	4	0.45	4	50		
5 LNB 050602OL	0.25R	0.5	0.5	6	0.45	4	50		
5 LNB 060302OL	0.3R	0.6	0.6	3	0.55	4	50		
5 LNB 060402OL	0.3R	0.6	0.6	4	0.55	4	50		
5 LNB 060602OL	0.3R	0.6	0.6	6	0.55	4	50		
5 LNB 060802OL	0.3R	0.6	0.6	8	0.55	4	50		
5 LNB 080402OL	0.4R	0.8	0.8	4	0.75	4	50		
5 LNB 080602OL	0.4R	0.8	0.8	6	0.75	4	50		
5 LNB 080802OL	0.4R	0.8	0.8	8	0.75	4	50		
5 LNB 081002OL	0.4R	0.8	0.8	10	0.75	4	50		
5 LNB 100602TX	0.5R	1	1	6	0.95	4	50		
5 LNB 100802TX	0.5R	1	1	8	0.95	4	50		
5 LNB 101002TX	0.5R	1	1	10	0.95	4	50		
5 LNB 101202TX	0.5R	1	1	12	0.95	4	50		
5 LNB 150602TX	0.75R	1.5	1.5	6	1.45	4	50		
5 LNB 150802TX	0.75R	1.5	1.5	8	1.45	4	50		
5 LNB 151002TX	0.75R	1.5	1.5	10	1.45	4	50		
5 LNB 151202TX	0.75R	1.5	1.5	12	1.45	4	50		
5 LNB 151602TX	0.75R	1.5	1.5	16	1.45	4	50		
5 LNB 200802TX	1R	2	2	8	1.95	4	50		
5 LNB 201002TX	1R	2	2	10	1.95	4	50		
5 LNB 201202TX	1R	2	2	12	1.95	4	50		
5 LNB 201402TX	1R	2	2	14	1.95	4	50		
5 LNB 201602TX	1R	2	2	16	1.95	4	50		
5 LNB 202002TX	1R	2	2	20	1.95	4	50		

**5 LNR 四刃深溝加工用鎢鋼R角銑刀**

LNR (Corner Radius For Deep Processing, Long Neck), 4 Flutes

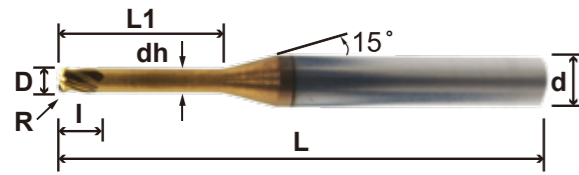

單位：mm (Unit : mm)

產品編號 Model No.	刃徑 D × R角 R Diameter × Corner Radius	刃長 l Flute Length	有效長 L1 Effective Length	頸徑 dh Neck dia	柄徑 d Shank Diameter	全長 L Overall Length	價格 Price	備註
5 LNR 0601034TX	0.6 x 0.1R	0.6	3	0.55	4	50		
5 LNR 0601044TX	0.6 x 0.1R	0.6	4	0.55	4	50		
5 LNR 0601054TX	0.6 x 0.1R	0.6	5	0.55	4	50		
5 LNR 0801044TX	0.8 x 0.1R	0.8	4	0.75	4	50		
5 LNR 0801064TX	0.8 x 0.1R	0.8	6	0.75	4	50		
5 LNR 1002044TX	1 x 0.2R	1	4	0.95	4	50		
5 LNR 1002064TX	1 x 0.2R	1	6	0.95	4	50		
5 LNR 1002084TX	1 x 0.2R	1	8	0.95	4	50		
5 LNR 1002104TX	1 x 0.2R	1	10	0.95	4	50		
5 LNR 1502064TX	1.5 x 0.2R	1.5	6	1.45	4	50		
5 LNR 1502084TX	1.5 x 0.2R	1.5	8	1.45	4	50		
5 LNR 1502104TX	1.5 x 0.2R	1.5	10	1.45	4	50		
5 LNR 1502124TX	1.5 x 0.2R	1.5	12	1.45	4	50		
5 LNR 1505064TX	1.5 x 0.5R	1.5	6	1.45	4	50		
5 LNR 1505084TX	1.5 x 0.5R	1.5	8	1.45	4	50		
5 LNR 1505104TX	1.5 x 0.5R	1.5	10	1.45	4	50		
5 LNR 1505124TX	1.5 x 0.5R	1.5	12	1.45	4	50		
5 LNR 2002084TX	2 x 0.2R	2	8	1.95	4	50		
5 LNR 2002104TX	2 x 0.2R	2	10	1.95	4	50		
5 LNR 2002124TX	2 x 0.2R	2	12	1.95	4	50		
5 LNR 2002164TX	2 x 0.2R	2	16	1.95	4	50		
5 LNR 2005084TX	2 x 0.5R	2	8	1.95	4	50		
5 LNR 2005104TX	2 x 0.5R	2	10	1.95	4	50		
5 LNR 2005124TX	2 x 0.5R	2	12	1.95	4	50		
5 LNR 2005164TX	2 x 0.5R	2	16	1.95	4	50		

備註：其他規格，請來電洽詢。

適用材質：

★最適合 ●適合 ▲佳

碳素鋼 Carbon steels	合金鋼 Alloy steel	預硬鋼材 Pre-hardened steels	高硬度鋼 High-hardened					不銹鋼 Stainless steels	鈦合金 Titanium alloys	鎳基合金 Nickel Based alloys	銅合金 Copper alloys	鋁合金 Aluminum alloys
		~HRC45	~HRC50	~HRC55	~HRC60	~HRC65						
★	★	★	★	●			●			●		



**鋁用銑刀**

垂直度極佳 加工面精細  
大切深、高進給 銅鋁合金專用

**高效率  
加工用刀具**

全方位切削工具服務



**成型刀訂製**

請提供訂製圖面並標示規格及  
是否需要塗層，製作數量。  
有任何問題歡迎來電詢問



專業刀具製造廠  
Specialized cutting tool factory



**638 SE4 高速・高硬度專用四刃鎢鋼立銑刀**    

SE4 (Regular Length, For High Hardness Material), 4 Flutes

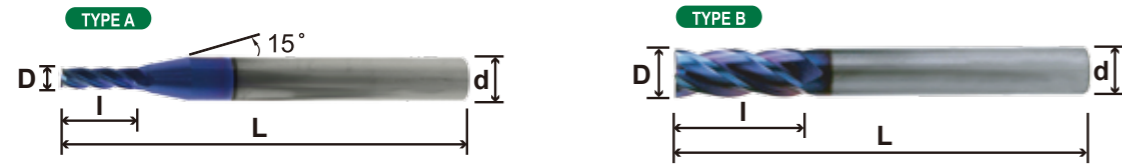



單位：mm (Unit : mm)

產品編號 Model No.	刃徑 D Diameter	刃長 l Flute Length	柄徑 d Shank Diameter	全長 L Overall Length	價格 Price	備註
638 MSE 0104NB	1	3	4	50		
638 MSE 0154NB	1.5	4	4	50		
638 MSE 0204NB	2	6	4	50		
638 MSE 0254NB	2.5	7	4	50		
638 MSE 0304NB	3	8	4	50		
638 MSE 0354NB	3.5	10	4	50		
638 MSE 0404NB	4	11	4	50		
638 SE 0404NB	4	11	6	50		
638 SE 0454NB	4.5	11	6	50		
638 SE 0504NB	5	13	6	50		
638 SE 0604NB	6	16	6	50		
638 SE 0704NB	7	18	8	60		
638 SE 0804NB	8	20	8	60		
638 SE 0904NB	9	23	10	75		
638 SE 1004NB	10	30	10	75		
638 SE 1104NB	11	30	12	75		
638 SE 1204NB	12	30	12	75		
638 SE 1404NB	14	40	16	100		
638 SE 1604NB	16	50	16	100		
638 SE 2004NB	20	50	20	100		

備註：其他規格，請來電洽詢。

適用材質： ★最適合 ●適合 ▲佳

碳素鋼 Carbon steels	合金鋼 Alloy steel	預硬鋼材 Pre-hardened steels	高硬度鋼 High-hardened				不銹鋼 Stainless steels	鈦合金 Titanium alloys	鎳基合金 Nickel Based alloys	銅合金 Copper alloys	鋁合金 Aluminum alloys
		~HRC45	~HRC50	~HRC55	~HRC60	~HRC65					
●	●	●	★	★	★	★					

**638 MSE2 高速・高硬度專用小徑鎢鋼立銑刀**    

MSE2 (Flat End Mill, For High Hardness Material), 2 Flutes-Micro Decimal Diameter

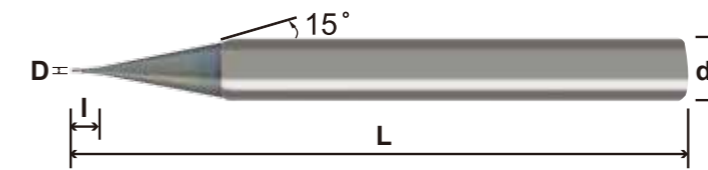

單位：mm (Unit : mm)

產品編號 Model No.	刃徑 D Diameter	刃長 l Flute Length	柄徑 d Shank Diameter	全長 L Overall Length	價格 Price	備註
638 MSE 0012OS	0.1	0.2	4	50		
638 MSE 0022OS	0.2	0.4	4	50		
638 MSE 0032OS	0.3	0.6	4	50		
638 MSE 0042OS	0.4	0.8	4	50		
638 MSE 0052OS	0.5	1.0	4	50		
638 MSE 0062OS	0.6	1.2	4	50		
638 MSE 0072OS	0.7	1.4	4	50		
638 MSE 0082OS	0.8	1.6	4	50		
638 MSE 0092OS	0.9	1.8	4	50		

備註：其他規格，請來電洽詢。

適用材質： ★最適合 ●適合 ▲佳

碳素鋼 Carbon steels	合金鋼 Alloy steel	預硬鋼材 Pre-hardened steels	高硬度鋼 High-hardened				不銹鋼 Stainless steels	鈦合金 Titanium alloys	鎳基合金 Nickel Based alloys	銅合金 Copper alloys	鋁合金 Aluminum alloys
		~HRC45	~HRC50	~HRC55	~HRC60	~HRC65					
●	●	●	★	★	★	★					

638 MSE2 / SE2 高速・高硬度二刃鎢鋼立銑刀   

MSE2/SE2 (Regular Length, For High Hardness Material), 2 Flutes

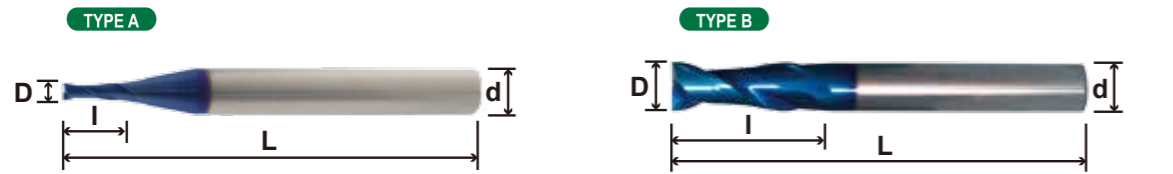

單位：mm (Unit : mm)

產品編號 Model No.	刃徑 D Diameter	刃長 l Flute Length	柄徑 d Shank Diameter	全長 L Overall Length	價格 Price	備註
638 MSE 0102NB	1	3	4	50		
638 MSE 0152NB	1.5	4	4	50		
638 MSE 0202NB	2	6	4	50		
638 MSE 0252NB	2.5	7	4	50		
638 MSE 0302NB	3	8	4	50		
638 SE 0302NB	3	8	6	50		
638 SE 0352NB	3.5	10	6	50		
638 MSE 0402NB	4	11	4	50		
638 SE 0402NB	4	11	6	50		
638 SE 0502NB	5	13	6	50		
638 SE 0602NB	6	16	6	50		

備註：其他規格，請來電洽詢。

適用材質：

★最適合 ●適合 ▲佳

碳素鋼 Carbon steels	合金鋼 Alloy steel	預硬鋼材	高硬度鋼					不銹鋼 Stainless steels	鈦合金 Titanium alloys	鎳基合金 Nickel Based alloys	銅合金 Copper alloys	鋁合金 Aluminum alloys
		Pre-hardened steels	High-hardened									
		~HRC45	~HRC50	~HRC55	~HRC60	~HRC65						
●	●	●	★	★	★	★						

638 MSP6 高速・高硬度專用六刃鎢鋼立銑刀   

MSP6 (High Hardness Material), 6 Flutes

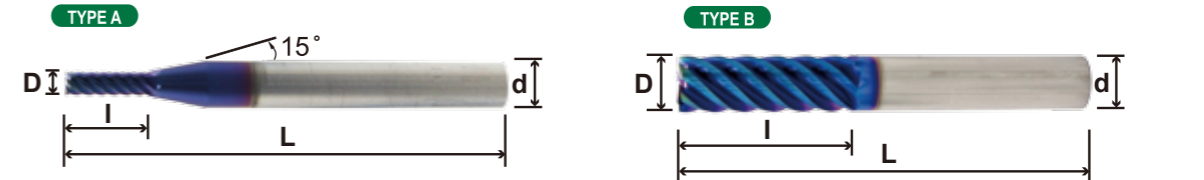

單位：mm (Unit : mm)

產品編號 Model No.	刃徑 D Diameter	刃長 l Flute Length	柄徑 d Shank Diameter	全長 L Overall Length	價格 Price	備註
638 MSP 0306NB	3	8	6	50		
638 MSP 0406NB	4	11	6	50		
638 MSP 0506NB	5	13	6	50		
638 MSP 0606NB	6	15	6	50		
638 MSP 0806NB	8	20	8	60		
638 MSP 1006NB	10	30	10	75		
638 MSP 1206NB	12	30	12	75		
638 MSP 1606NB	16	50	16	100		
638 MSP 2006NB	20	50	20	100		

備註：其他規格，請來電洽詢。

638 MLP6 高速・高硬度專用六刃長刃鎢鋼立銑刀

MLP6 (High Hardness Material, Long Flute Length), 6 Flutes

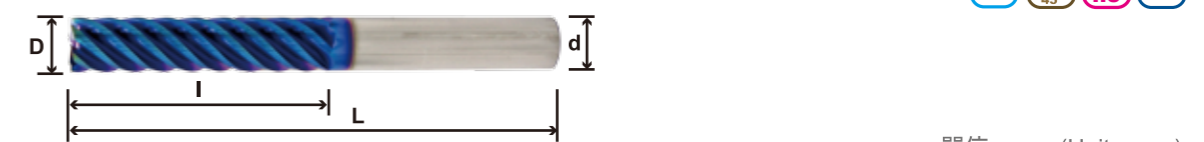

單位：mm (Unit : mm)

產品編號 Model No.	刃徑 D Diameter	刃長 l Flute Length	柄徑 d Shank Diameter	全長 L Overall Length	價格 Price	備註
638 MLP 0606NB	6	30	6	75		
638 MLP 0806NB	8	40	8	100		
638 MLP 1006NB	10	50	10	100		
638 MLP 1206NB	12	50	12	100		
638 MLP 1606NB	16	80	16	150		
638 MLP 2006NB	20	80	20	150		

備註：其他規格，請來電洽詢。

適用材質：

★最適合 ●適合 ▲佳

碳素鋼 Carbon steels	合金鋼 Alloy steel	預硬鋼材	高硬度鋼					不銹鋼 Stainless steels	鈦合金 Titanium alloys	鎳基合金 Nickel Based alloys	銅合金 Copper alloys	鋁合金 Aluminum alloys
		Pre-hardened steels	High-hardened									
		~HRC45	~HRC50	~HRC55	~HRC60	~HRC65						
●	●	●	★	★	★	★						

**638 MSB2 / SB2 二刃鎢鋼球刀**

MSB2 (Ball Nose), 2 Flutes

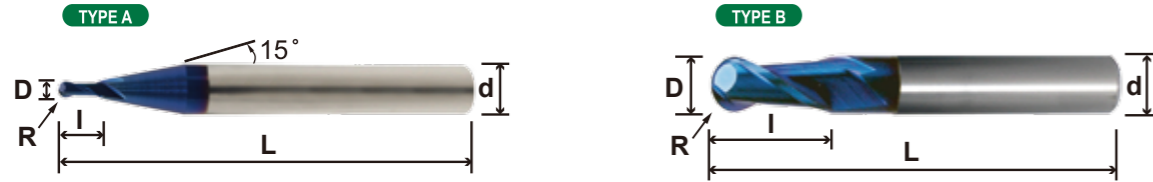

單位：mm (Unit : mm)

產品編號 Model No.	球頭半徑 R Radius	刃徑 D Diameter	刃長 I Flute Length	柄徑 d Shank Diameter	全長 L Overall Length	價格 Price	備註
638 MSB 0102NB	0.5R	1	2	4	50		
638 SB 0102NB	0.5R	1	2	6	50		
638 MSB 0152NB	0.75R	1.5	3	4	50		
638 SB 0152NB	0.75R	1.5	3	6	50		
638 MSB 0202NB	1R	2	4	4	50		
638 SB 0202NB	1R	2	4	6	50		
638 MSB 0252NB	1.25R	2.5	5	4	50		
638 SB 0252NB	1.25R	2.5	5	6	50		
638 SSB 0302NB	1.5R	3	6	3	50		
638 MSB 0302NB	1.5R	3	6	4	50		
638 SB 0302NB	1.5R	3	6	6	50		
638 MSB 0352NB	1.75R	3.5	7	4	50		
638 MSB 0402NB	2R	4	8	4	50		
638 SB 0402NB	2R	4	8	6	50		
638 SB 0452NB	2.25R	4.5	9	6	50		
638 SB 0502NB	2.5R	5	10	6	50		
638 SB 0602NB	3R	6	12	6	50		
638 SB 0702NB	3.5R	7	14	8	60		
638 SB 0802NB	4R	8	16	8	60		
638 SB 0902NB	4.5R	9	18	10	75		
638 SB 1002NB	5R	10	20	10	75		
638 SB 1102NB	5.5R	11	22	12	75		
638 SB 1202NB	6R	12	24	12	75		
638 SB 1402NB	7R	14	28	16	75		
638 SB 1602NB	8R	16	32	16	100		
638 SB 2002NB	10R	20	40	20	100		

**638 MSB 高速·高硬度用小徑鎢鋼球刀**

MSB (Ball Nose, For High Hardness Material), 2 Flutes-Micro Diameter

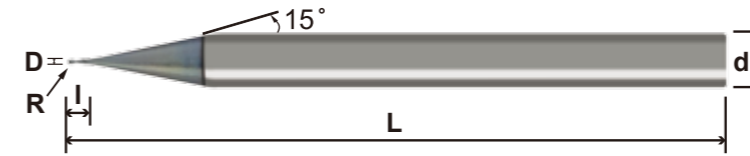

單位：mm (Unit : mm)

產品編號 Model No.	球頭半徑 R Radius	刃徑 D Diameter	刃長 I Flute Length	柄徑 d Shank Diameter	全長 L Overall Length	價格 Price	備註
638 MSB 0022OS	0.1R	0.2	0.4	4	50		
638 MSB 0032OS	0.15R	0.3	0.6	4	50		
638 MSB 0042OS	0.2R	0.4	0.8	4	50		
638 MSB 0052OS	0.25R	0.5	1	4	50		
638 MSB 0062OS	0.3R	0.6	1.2	4	50		
638 MSB 0082OS	0.4R	0.8	1.6	4	50		

備註：其他規格，請來電洽詢。

適用材質：

★最適合 ●適合 ▲佳

碳素鋼 Carbon steels	合金鋼 Alloy steel	預硬鋼材 Pre-hardened steels	高硬度鋼 High-hardened				不銹鋼 Stainless steels	鈦合金 Titanium alloys	鎳基合金 Nickel Based alloys	銅合金 Copper alloys	鋁合金 Aluminum alloys
		~HRC45	~HRC50	~HRC55	~HRC60	~HRC65					
●	●	●	★	★	★	★					

638 SLB2 / MLB2 / LLB2 二刃長柄鎢鋼球刀



SLB2/MLB2/LLB2 (Ball Nose, Long Shank), 2 Flutes

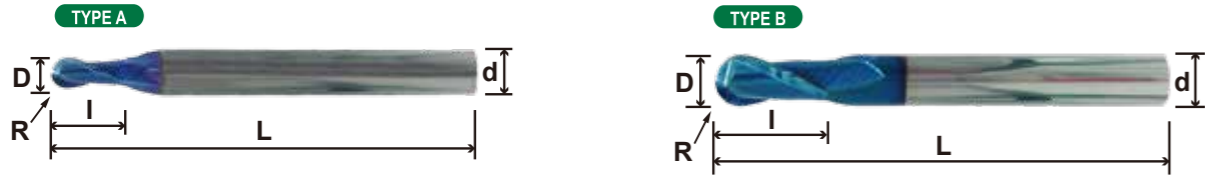

單位：mm (Unit : mm)

產品編號 Model No.	球頭半徑 R Radius	刃徑 D Diameter	刃長 I Flute Length	柄徑 d Shank Diameter	全長 L Overall Length	價格 Price	備註
638 SLB 0102NB	0.5R	1	2	4	75		
638 SLB 0102NB	0.5R	1	2	6	75		
638 MLB 0102NB	0.5R	1	2	4	100		
638 MLB 0102NB	0.5R	1	2	6	100		
638 SLB 0152NB	0.75R	1.5	3	4	75		
638 SLB 0152NB	0.75R	1.5	3	6	75		
638 MLB 0152NB	0.75R	1.5	3	4	100		
638 MLB 0152NB	0.75R	1.5	3	6	100		
638 SLB 0202NB	1R	2	4	4	75		
638 SLB 0202NBD6	1R	2	4	6	75		
638 MLB 0202NB	1R	2	4	4	100		
638 MLB 0202NBD6	1R	2	4	6	100		
638 SLB 0252NB	1.25R	2.5	5	4	75		
638 SLB 0252NBD6	1.25R	2.5	5	6	75		
638 MLB 0252NB	1.25R	2.5	5	4	100		
638 MLB 0252NBD6	1.25R	2.5	5	6	100		
638 SLB 0302NBD3	1.5R	3	6	3	75		
638 SLB 0302NB	1.5R	3	6	4	75		
638 SLB 0302NBD6	1.5R	3	6	6	75		
638 MLB 0302NBD3	1.5R	3	6	3	100		
638 MLB 0302NB	1.5R	3	6	4	100		
638 MLB 0302NBD6	1.5R	3	6	6	100		
638 SLB 0402NB	2R	4	8	4	75		
638 SLB 0402NBD6	2R	4	8	6	75		
638 MLB 0402NB	2R	4	8	4	100		
638 MLB 0402NBD6	2R	4	8	6	100		

備註：其他規格，請來電洽詢。

適用材質：

★最適合 ●適合 ▲佳

碳素鋼 Carbon steels	合金鋼 Alloy steel	預硬鋼材 Pre-hardened steels	高硬度鋼 High-hardened					不銹鋼 Stainless steels	鈦合金 Titanium alloys	鎳基合金 Nickel Based alloys	銅合金 Copper alloys	鋁合金 Aluminum alloys
		~HRC45	~HRC50	~HRC55	~HRC60	~HRC65						
●	●	●	★	★	★	★						

單位：mm (Unit : mm)

產品編號 Model No.	球頭半徑 R Radius	刃徑 D Diameter	刃長 I Flute Length	柄徑 d Shank Diameter	全長 L Overall Length	價格 Price	備註
638 SLB 0502NB	2.5R	5	10	6	75		
638 MLB 0502NB	2.5R	5	10	6	100		
638 SLB 0602NB	3R	6	12	6	75		
638 MLB 0602NB	3R	6	12	6	100		
638 SLB 0802NB	4R	8	16	8	75		
638 MLB 0802NB	4R	8	16	8	100		
638 LLB 0802NB	4R	8	16	8	150		
638 MLB 1002NB	5R	10	20	10	100		
638 LLB 1002NB	5R	10	20	10	150		
638 MLB 1202NB	6R	12	24	12	100		
638 LLB 1202NB	6R	12	24	12	150		
638 MLB 1602NB	8R	16	32	16	150		
638 LLB 1602NB	8R	16	32	16	200		
638 MLB 2002NB	10R	20	40	20	150		
638 LLB 2002NB	10R	20	40	20	200		

**638 RTA 四刃鎢鋼R角銑刀**

RTA (Conner Radius),4 Flutes

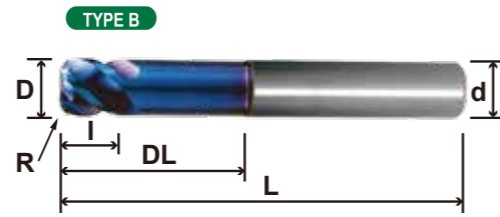
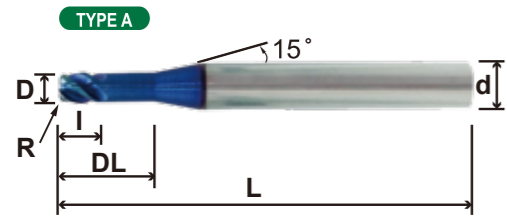

單位：mm (Unit : mm)

產品編號 Model No.	刃徑 D × R角 R Diameter × Corner Radius	刃長 I Flute Length	有效長 DL Effective Length	柄徑 d Shank Diameter	全長 L Overall Length	價格 Price	備註
638 RTA 0040012OS	0.4 × 0.1R	0.4		4	50		
638 RTA 0050012OS	0.5 × 0.1R	0.5		4	50		
638 RTA 0060012OS	0.6 × 0.1R	0.6	2	4	50		
638 RTA 0080014OS	0.8 × 0.1R	0.8	2.5	4	50		
638 RTA 010014NB	1 × 0.1R	1	3	4	50		
638 RTA 010024NB	1 × 0.2R	1	3	4	50		
638 RTA 015014NB	1.5 × 0.1R	1.5	5	4	50		
638 RTA 015024NB	1.5 × 0.2R	1.5	5	4	50		
638 RTA 015054NB	1.5 × 0.5R	1.5	5	4	50		
638 RTA 020014NB	2 × 0.1R	2	6	4	50		
638 RTA 020024NB	2 × 0.2R	2	6	4	50		
638 RTA 020054NB	2 × 0.5R	2	6	4	50		
638 RTA 025024NB	2.5 × 0.2R	2.5	8	4	50		
638 RTA 025054NB	2.5 × 0.5R	2.5	8	4	50		
638 RTA 030014NB	3 × 0.1R	3	10	4	50		
638 RTA 030024NBD3	3 × 0.2R	3	10	3	50		
638 RTA 030024NB	3 × 0.2R	3	10	4	50		
638 RTA 030024NBD6	3 × 0.2R	3	10	6	50		
638 RTA 030054NBD3	3 × 0.5R	3	10	3	50		
638 RTA 030054NB	3 × 0.5R	3	10	4	50		
638 RTA 030054NBD6	3 × 0.5R	3	10	6	50		
638 RTA 030104NBD3	3 × 1R	3	10	3	50		
638 RTA 030104NB	3 × 1R	3	10	4	50		
638 RTA 030104NBD6	3 × 1R	3	10	6	50		
638 RTA 040014NB	4 × 0.1R	4	12	4	50		
638 RTA 040024NB	4 × 0.2R	4	12	4	50		
638 RTA 040024NBD6	4 × 0.2R	4	12	6	50		
638 RTA 040054NB	4 × 0.5R	4	12	4	50		
638 RTA 040054NBD6	4 × 0.5R	4	12	6	50		
638 RTA 040104NB	4 × 1R	4	12	4	50		
638 RTA 040104NBD6	4 × 1R	4	12	6	50		

單位：mm (Unit : mm)

產品編號 Model No.	刃徑 D × R角 R Diameter × Corner Radius	刃長 I Flute Length	有效長 DL Effective Length	柄徑 d Shank Diameter	全長 L Overall Length	價格 Price	備註
638 RTA 050054NB	5 × 0.5R	5	15	6	50		
638 RTA 050104NB	5 × 1R	5	15	6	50		
638 RTA 060024NB	6 × 0.2R	6	18	6	50		
638 RTA 060054NB	6 × 0.5R	6	18	6	50		
638 RTA 060104NB	6 × 1R	6	18	6	50		
638 RTA 060154NB	6 × 1.5R	6	18	6	50		
638 RTA 080024NB	8 × 0.2R	8	24	8	60		
638 RTA 080054NB	8 × 0.5R	8	24	8	60		
638 RTA 080104NB	8 × 1R	8	24	8	60		
638 RTA 080204NB	8 × 2R	8	24	8	60		
638 RTA 100054NB	10 × 0.5R	10	30	10	75		
638 RTA 100104NB	10 × 1R	10	30	10	75		
638 RTA 100204NB	10 × 2R	10	30	10	75		
638 RTA 120054NB	12 × 0.5R	12	36	12	75		
638 RTA 120104NB	12 × 1R	12	36	12	75		
638 RTA 120204NB	12 × 2R	12	36	12	75		
638 RTA 120304NB	12 × 3R	12	36	12	75		

備註：其他規格，請來電洽詢。

適用材質：

★最適合 ●適合 ▲佳

碳素鋼 Carbon steels	合金鋼 Alloy steel	預硬鋼材 Pre-hardened steels	高硬度鋼 High-hardened					不銹鋼 Stainless steels	鈦合金 Titanium alloys	鎳基合金 Nickel Based alloys	銅合金 Copper alloys	鋁合金 Aluminum alloys
		~HRC45	~HRC50	~HRC55	~HRC60	~HRC65						
●	●	●	★	★	★	★						

638 SLR4 / MLR4 四刃長柄鎢鋼R角銑刀



SLR4/MLR4 (Corner Radius, Long Shank), 4 Flutes

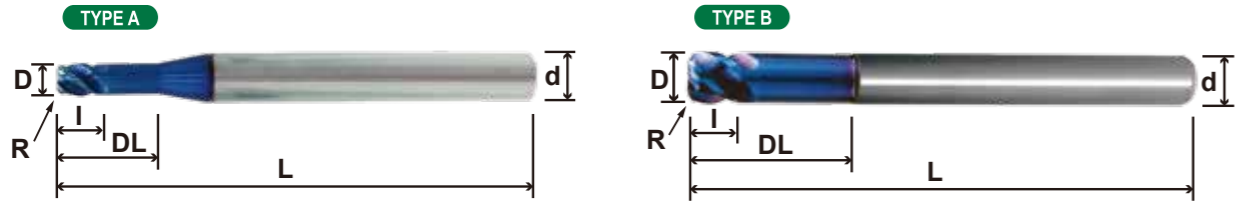

單位 : mm (Unit : mm)

產品編號 Model No.	刃徑 × R角 Diameter × Corner Radius	刃長 Flute Length	有效長 Effective Length	柄徑 Shank Diameter	全長 Overall Length	價格 Price	備註
638 SLR 010024NB	1 × 0.2R	1	3	4	75		
638 SLR 010024NBD6	1 × 0.2R	1	3	6	75		
638 MLR 010024NB	1 × 0.2R	1	3	4	100		
638 MLR 010024NBD6	1 × 0.2R	1	3	6	100		
638 SLR 015024NB	1.5 × 0.2R	1.5	5	4	75		
638 SLR 015024NBD6	1.5 × 0.2R	1.5	5	6	75		
638 MLR 015024NB	1.5 × 0.2R	1.5	5	4	100		
638 MLR 015024NBD6	1.5 × 0.2R	1.5	5	6	100		
638 SLR 020024NB	2 × 0.2R	2	6	4	75		
638 SLR 020024NBD6	2 × 0.2R	2	6	6	75		
638 MLR 020024NB	2 × 0.2R	2	6	4	100		
638 MLR 020024NBD6	2 × 0.2R	2	6	6	100		
638 SLR 020054NB	2 × 0.5R	2	6	4	75		
638 SLR 020054NBD6	2 × 0.5R	2	6	6	75		
638 MLR 020054NB	2 × 0.5R	2	6	4	100		
638 MLR 020054NBD6	2 × 0.5R	2	6	6	100		
638 SLR 030024NBD3	3 × 0.2R	3	10	3	75		
638 SLR 030024NB	3 × 0.2R	3	10	4	75		
638 SLR 030024NBD6	3 × 0.2R	3	10	6	75		
638 MLR 030024NBD3	3 × 0.2R	3	10	3	100		
638 MLR 030024NB	3 × 0.2R	3	10	4	100		
638 MLR 030024NBD6	3 × 0.2R	3	10	6	100		
638 SLR 030054NBD3	3 × 0.5R	3	10	3	75		
638 SLR 030054NB	3 × 0.5R	3	10	4	75		
638 SLR 030054NBD6	3 × 0.5R	3	10	6	75		
638 MLR 030054NBD3	3 × 0.5R	3	10	3	100		
638 MLR 030054NB	3 × 0.5R	3	10	4	100		
638 MLR 030054NBD6	3 × 0.5R	3	10	6	100		
638 SLR 040024NB	4 × 0.2R	4	12	4	75		
638 SLR 040024NBD6	4 × 0.2R	4	12	6	75		
638 MLR 040024NB	4 × 0.2R	4	12	4	100		
638 MLR 040024NBD6	4 × 0.2R	4	12	6	100		
638 SLR 040054NB	4 × 0.5R	4	12	4	75		
638 SLR 040054NBD6	4 × 0.5R	4	12	6	75		
638 MLR 040054NB	4 × 0.5R	4	12	4	100		
638 MLR 040054NBD6	4 × 0.5R	4	12	6	100		

單位 : mm (Unit : mm)

產品編號 Model No.	刃徑 × R角 Diameter × Corner Radius	刃長 Flute Length	有效長 Effective Length	柄徑 Shank Diameter	全長 Overall Length	價格 Price	備註
638 SLR 040104NB	4 × 1R	4	12	4	75		
638 SLR 040104NBD6	4 × 1R	4	12	6	75		
638 MLR 040104NB	4 × 1R	4	12	4	100		
638 MLR 040104NBD6	4 × 1R	4	12	6	100		
638 SLR 060024NB	6 × 0.2R	6	18	6	75		
638 MLR 060024NB	6 × 0.2R	6	18	6	100		
638 SLR 060054NB	6 × 0.5R	6	18	6	75		
638 MLR 060054NB	6 × 0.5R	6	18	6	100		
638 SLR 060104NB	6 × 1R	6	18	6	75		
638 MLR 060104NB	6 × 1R	6	18	6	100		
638 SLR 080024NB	8 × 0.2R	8	24	6	75		
638 MLR 080024NB	8 × 0.2R	8	24	6	100		
638 SLR 080054NB	8 × 0.5R	8	24	8	75		
638 MLR 080054NB	8 × 0.5R	8	24	8	100		
638 SLR 080104NB	8 × 1R	8	24	8	75		
638 MLR 080104NB	8 × 1R	8	24	8	100		
638 SLR 080204NB	8 × 2R	8	24	8	75		
638 MLR 080204NB	8 × 2R	8	24	8	100		
638 MLR 100054NB	10 × 0.5R	10	30	10	100		
638 MLR 100104NB	10 × 1R	10	30	10	100		
638 MLR 100204NB	10 × 2R	10	30	10	100		
638 MLR 120054NB	12 × 0.5R	12	36	12	100		
638 MLR 120104NB	12 × 1R	12	36	12	100		
638 MLR 120204NB	12 × 2R	12	36	12	100		
638 MLR 120304NB	12 × 3R	12	36	12	100		

備註：其他規格，請來電洽詢。

適用材質：

★最適 ●適合 ▲佳

碳素鋼 Carbon steels	合金鋼 Alloy steel	預硬鋼材 Pre-hardened steels		高硬度鋼 High-hardened			不銹鋼 Stainless steels	鈦合金 Titanium alloys	鎳基合金 Nickel Based alloys	銅合金 Copper alloys	鋁合金 Aluminum alloys
		~HRC45	~HRC50	~HRC55	~HRC60	~HRC65					
●	●	●	★	★	★	★					

**2D 5 TMAE 車銑複合機專用鋁用立銑刀**

TMAE (Compound Lathe End Mill for Aluminum Alloy), 3 Flutes

單位：mm (Unit : mm)

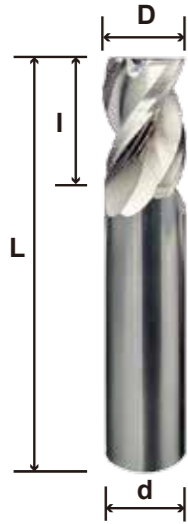

產品編號 Model No.	刃徑 D Diameter	刃長 I Flute Length	柄徑 d Shank Diameter	全長 L Overall Length	價格 Price	備註
2D TMAE 0103	1	1.5	6	50		
2D TMAE 0153	1.5	2.5	6	50		
2D TMAE 0203	2	3	6	50		
2D TMAE 0253	2.5	4	6	50		
2D TMAE 0303	3	4.5	6	50		
2D TMAE 0403	4	6	6	50		
2D TMAE 0503	5	8	6	50		
2D TMAE 0603	6	9	6	50		
2D TMAE 0803	8	12	8	50		
2D TMAE 1003	10	15	10	50		
2D TMAE 1203	12	18	12	60		
2D TMAE 1603	16	24	12	60		

備註：其他規格，請來電洽詢。

**2D 5 TMTAE 車銑複合機專用小柄鋁用立銑刀**

TMTAE (Compound Lathe End Mill for Aluminum Alloy-Small handle), 3 Flutes

單位：mm (Unit : mm)

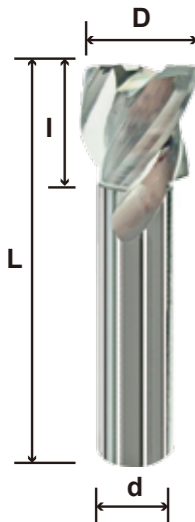

產品編號 Model No.	刃徑 D Diameter	刃長 I Flute Length	柄徑 d Shank Diameter	全長 L Overall Length	價格 Price	備註
2D TMTAE 0803	8	8	6	30		
2D TMTAE 1003	10	10	6	35		
2D TMTAE 1203	12	12	6	40		

備註：其他規格，請來電洽詢。

適用材質：

★最適合 ●適合 ▲佳

碳素鋼 Carbon steels	合金鋼 Alloy steel	預硬鋼材 Pre-hardened steels		高硬度鋼 High-hardened			不銹鋼 Stainless steels	鈦合金 Titanium alloys	鎳基合金 Nickel Based alloys	銅合金 Copper alloys	鋁合金 Aluminum alloys
		~HRC45	~HRC50	~HRC55	~HRC60	~HRC65					
										★	★

**2D 5 TMSB 車銑複合機專用鎢鋼球型銑刀**

TMSB (Compound Lathe Ball Nose End Mill), 2 Flutes

單位：mm (Unit : mm)

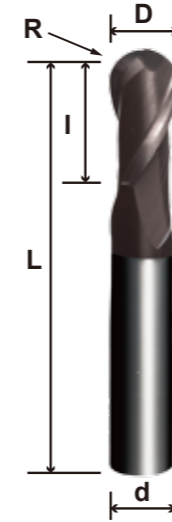

產品編號 Model No.	球頭半徑 R Radius	刃徑 D Diameter	刃長 I Flute Length	柄徑 d Shank Diameter	全長 L Overall Length	價格 Price	備註
2D TMSB 0102R7	0.5R	1	1.5	6	50		
2D TMSB 0152R7	0.75R	1.5	2.5	6	50		
2D TMSB 0202R7	1R	2	3	6	50		
2D TMSB 0302R7	1.5R	3	4.5	6	50		
2D TMSB 0402R7	2R	4	6	6	50		
2D TMSB 0502R7	2.5R	5	8	6	50		
2D TMSB 0602R7	3R	6	9	6	50		
2D TMSB 0802R7	4R	8	12	8	50		
2D TMSB 1002R7	5R	10	15	10	50		
2D TMSB 1202R7	6R	12	18	12	60		
2D TMSB 1602R7	8R	16	24	12	60		

備註：其他規格，請來電洽詢。

**2D 5 TMTSB 車銑複合機專用小柄球銑刀**

TMTSB (Compound Lathe Ball Nose End Mill-Small handle), 2 Flutes

單位：mm (Unit : mm)

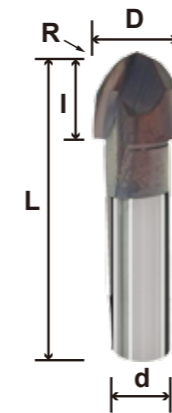

產品編號 Model No.	球頭半徑 R Radius	刃徑 D Diameter	刃長 I Flute Length	柄徑 d Shank Diameter	全長 L Overall Length	價格 Price	備註
2D TMTSB 0802R7	4R	8	8	6	30		
2D TMTSB 1002R7	5R	10	10	6	35		
2D TMTSB 1202R7	6R	12	12	6	40		

備註：其他規格，請來電洽詢。

適用材質：

★最適合 ●適合 ▲佳

碳素鋼 Carbon steels	合金鋼 Alloy steel	預硬鋼材 Pre-hardened steels		高硬度鋼 High-hardened			不銹鋼 Stainless steels	鈦合金 Titanium alloys	鎳基合金 Nickel Based alloys	銅合金 Copper alloys	鋁合金 Aluminum alloys
		~HRC45	~HRC50	~HRC55	~HRC60	~HRC65					
★	★	★					★	●	●	●	●

**2D 5 TMPE 車銑複合機專用三刃立銑刀** (R7) (45) (SHANK h5)

TMPE (For Compound Lathe End Mill), 3 Flutes

單位：mm (Unit : mm)

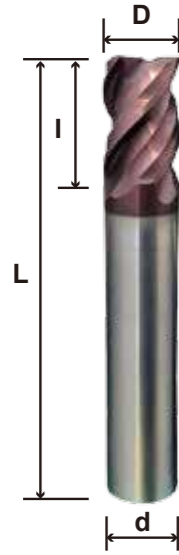

產品編號 Model No.	刃徑 D Diameter	刃長 I Flute Length	柄徑 d Shank Diameter	全長 L Overall Length	價格 Price	備註
2D TMPE 0103R7D4	1	1.5	4	50		
2D TMPE 0103R7	1	1.5	6	50		
2D TMPE 0153R7	1.5	2.5	6	50		
2D TMPE 0203R7	2	3	6	50		
2D TMPE 0253R7	2.5	4	6	50		
2D TMPE 0303R7	3	4.5	6	50		
2D TMPE 0403R7D4	4	6	4	50		
2D TMPE 0403R7	4	6	6	50		
2D TMPE 0503R7	5	8	6	50		
2D TMPE 0603R7	6	9	6	50		
2D TMPE 0703R7	7	11	8	50		
2D TMPE 0803R7	8	12	8	50		
2D TMPE 1003R7	10	15	10	60		
2D TMPE 1203R7	12	18	12	60		
2D TMPE 1603R7	16	24	12	60		

備註：其他規格，請來電洽詢。

**2D 5 TMTPE 車銑複合機專用小柄立銑刀** (R7) (45) (SHANK h5)

TMTPE (For Compound Lathe End Mill-Small handle mill), 3 Flutes

單位：mm (Unit : mm)

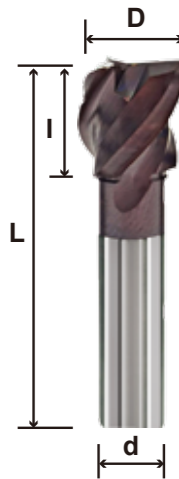

產品編號 Model No.	刃徑 D Diameter	刃長 I Flute Length	柄徑 d Shank Diameter	全長 L Overall Length	價格 Price	備註
2D TMTPE 0803R7	8	8	6	30		
2D TMTPE 1003R7	10	10	6	35		
2D TMTPE 1203R7	12	12	6	40		

備註：其他規格，請來電洽詢。

適用材質：

★最適合 ●適合 ▲佳

碳素鋼 Carbon steels	合金鋼 Alloy steel	預硬鋼材 Pre-hardened steels					高硬度鋼 High-hardened					不銹鋼 Stainless steels	鈦合金 Titanium alloys	鎳基合金 Nickel Based alloys	銅合金 Copper alloys	鋁合金 Aluminum alloys
		~HRC45					~HRC50	~HRC55	~HRC60	~HRC65						
★	★	★									★	●	●	●	●	●

**VUA 鎢鋼螺旋銑牙刀- ISO規格 (三峰)**

VUA(Thread Milling Tools-Helical Flutes-ISO Metric)Three teeth

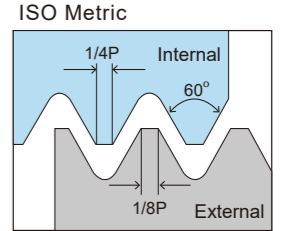

Defined by: R262 (DIN 13)  
Tolerance class: 6H

單位：mm (Unit : mm)

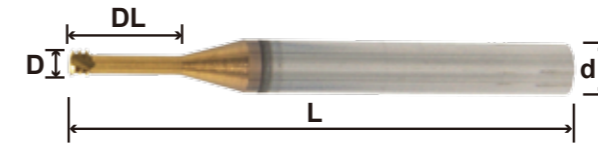

產品編號 Model No.	牙尺寸 Thread	牙距 MM Pitch	外徑 D Diameter	有效長 DL Effective Length	刃數 T Flute	柄徑 d Shank Diameter	全長 L Overall Length	價格 Price	備註
5 VUA 01050303TX	M1.4 × 0.3	0.3	1.05	2.8	3T	4	50		
5 VUA 01200353TX	M1.6 × 0.35	0.35	1.2	3.2	3T	4	50		
5 VUA 01550403TX	M2 × 0.4	0.4	1.55	4	3T	4	50		
5 VUA 01950453TX	M2.5 × 0.45	0.45	1.95	5	3T	4	50		
5 VUA 02300503TX	M3 × 0.5	0.5	2.3	6	3T	4	50		
5 VUA 03200703TX	M4 × 0.7	0.7	3.2	8	3T	6	60		
5 VUA 04000803TX	M5 × 0.8	0.8	4	10	3T	6	60		
5 VUA 04801003TX	M6 × 1.0	1.0	4.8	12	3T	6	75		

備註：其他規格，請來電洽詢。

**VUB 鎢鋼螺旋銑牙刀- ISO規格 (全齒)**

VUB(Thread Milling Tools-Helical Flutes-ISO Metric)-Full teeth

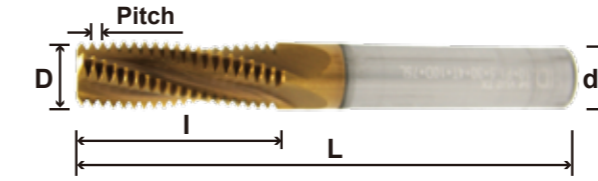

單位：mm (Unit : mm)

產品編號 Model No.	牙尺寸 Thread	牙距 MM Pitch	外徑 D Diameter	刃長 I Flute Length	刃數 T Flute	柄徑 d Shank Diameter	全長 L Overall Length	價格 Price	備註
5 VUB 02300503TX	M3 × 0.5	0.5	2.3	6	3T	6	50		
5 VUB 03100703TX	M4 × 0.7	0.7	3.1	10	3T	6	50		
5 VUB 04000803TX	M5 × 0.8	0.8	4	13	3T	6	60		
5 VUB 04801003TX	M6 × 1.0	1.0	4.8	15	3T	6	60		
5 VUB 06001253TX	M8 × 1.25	1.25	6	20	3T	6	60		
5 VUB 08001503TX	M10 × 1.5	1.5	8	20	3T	8	75		
5 VUB 10001754TX	M12 × 1.75	1.75	10	30	4T	10	75		
5 VUB 10002004TX	M14 × 2.0	2.0	10	36	4T	10	75		
5 VUB 12002004TX	M16 × 2.0	2.0	12	36	4T	12	100		

備註：其他規格，請來電洽詢。

適用材質：

★最適合 ●適合 ▲佳

碳素鋼 Carbon steels	合金鋼 Alloy steel	預硬鋼材 Pre-hardened steels					高硬度鋼 High-hardened					不銹鋼 Stainless steels	鈦合金 Titanium alloys	鎳基合金 Nickel Based alloys	銅合金 Copper alloys	鋁合金 Aluminum alloys
		~HRC45					~HRC50	~HRC55	~HRC60	~HRC65						
★	★	★					★	●	●	●	●	★	●		●	●



## VUA 鎢鋼銑牙刀-三峰-UN (內牙/外牙)

VUA(Tungsten Carbide Tread Milling Tools-American-UN (Internal/External))



單位：mm (Unit : mm)

產品編號 Model No.	Thread Size		螺距 MM Pitch	外徑 D Diameter	有效長 DL Effective Length	刃數 T Flute	柄徑 d Shank Diameter	全長 L Overall Length	價格 Price	備註
	粗牙 UNC	細牙 UNF								
5 VUA 014UN72TX		1-72UNF	72	1.4	3.8	3	4	50		
5 VUA 014UN64TX	1-64UNC	2-64UNF	64	1.4	3.9	3	4	50		
5 VUA 016UN56TX	2-56UNC	3-56UNF	56	1.6	4.6	3	4	50		
5 VUA 019UN48TX	3-48UNC	4-48UNF	48	1.9	5.4	3	4	50		
5 VUA 021UN40TX	4-40UNC		40	2.1	6.2	3	4	50		
5 VUA 024UN40TX	5-40UNC	6-40UNF	40	2.4	7.1	3	4	50		
5 VUA 033UN36TX		8-36UNF	36	3.3	8.8	3	4	50		
5 VUA 026UN32TX	6-32UNC		32	2.6	7.3	3	4	50		
5 VUA 032UN32TX	8-32UNC	10-32UNF	32	3.2	10.1	3	6	60		
5 VUA 052UN28TX		1/4-28UNF	28	5.2	14	3	6	60		
5 VUA 036UN24TX	10-24UNC		24	3.6	10.4	3	6	60		
5 VUA 048UN20TX	1/4-20UNC	7/16-20UNF	20	4.8	13.7	3	6	60		
5 VUA 060UN18TX	5/16-18UNC		18	6.0	16.5	3	6	60		

備註：其他規格，請來電洽詢。

適用材質：

★最適合 ●適合 ▲佳

碳素鋼 Carbon steels	合金鋼 Alloy steel	預硬鋼材 Pre-hardened steels		高硬度鋼 High-hardened			不銹鋼 Stainless steels	鈦合金 Titanium alloys	鎳基合金 Nickel Based alloys	銅合金 Copper alloys	鋁合金 Aluminum alloys
		~HRC45	~HRC50	~HRC55	~HRC60	~HRC65					
★	★	★	★	●	●	●	★	●		●	●

## VUB 鎢鋼銑牙刀- UN (內牙)

VUB Tungsten Carbide Tread Milling Tools-American-UN (Internal)

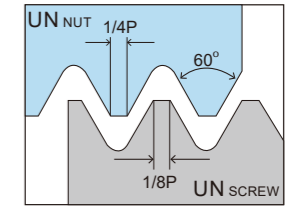
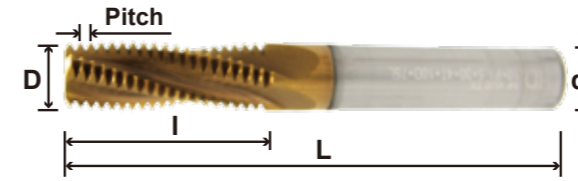

單位：mm (Unit : mm)

產品編號 Model No.	粗牙 UNC	細牙 UNF	極細牙 UNEF	螺距 P Pitch	外徑 D Diameter	牙長 l Flute Length	刃數 T Number of Flute	柄徑 d Shank Diameter	全長 L Overall Length	價格 Price	備註
5 VUB 06032UN			5/16	32	6.0	15	3	6	60		
5 VUB 08032UN			3/8	32	8.0	20	3	8	60		
5 VUB 05128UN		1/4		28	5.1	15	3	6	60		
5 VUB 08028UN			7/16-1/2	28	8.0	20	3	8	60		
5 VUB 06024UN		5/16		24	6.0	15	3	6	60		
5 VUB 08024UN		3/8		24	8.0	20	3	8	60		
5 VUB 12024UN		9/16-5/8		24	12.0	30	4	12	75		
5 VUB 04820UN	1/4			20	4.8	12	3	6	60		
5 VUB 08020UN		7/16		20	8.0	20	3	8	60		
5 VUB 10020UN		1/2		20	10.0	25	4	10	75		
5 VUB 12020UN			3/4-1	20	12.0	30	4	12	75		
5 VUB 06018UN	5/16			18	6.0	15	3	6	60		
5 VUB 10018UN		9/16-5/8		18	10.0	25	4	10	75		
5 VUB 07516UN	3/8			16	7.5	18.2	3	8	60		
5 VUB 12016UN		3/4		16	12.0	30	4	12	75		
5 VUB 08014UN	7/16			14	8.0	20	3	8	60		
5 VUB 12014UN		7/8		14	12.0	30	4	12	75		
5 VUB 10013UN	1/2			13	10.0	25	4	10	75		
5 VUB 11512UN	9/16			12	11.5	30	4	12	75		
5 VUB 16012UN		1		12	16.0	40	4	16	100		
5 VUB 12011UN	5/8			11	12.0	30	4	12	75		
5 VUB 16010UN	3/4			10	16.0	40	4	16	100		
5 VUB 16009UN	7/8			9	16.0	40	4	16	100		
5 VUB 20008UN	1			8	20.0	50	4	20	100		

備註：其他規格，請來電洽詢。

適用材質：

★最適合 ●適合 ▲佳

碳素鋼 Carbon steels	合金鋼 Alloy steel	預硬鋼材 Pre-hardened steels		高硬度鋼 High-hardened			不銹鋼 Stainless steels	鈦合金 Titanium alloys	鎳基合金 Nickel Based alloys	銅合金 Copper alloys	鋁合金 Aluminum alloys
		~HRC45	~HRC50	~HRC55	~HRC60	~HRC65					
★	★	★	★	●	●	●	★	●		●	●

## VUC 鎢鋼螺旋斜度銑牙刀

VUC (Taper Thread Milling Cutter)

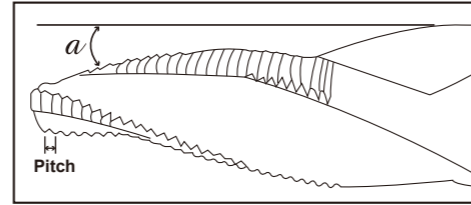
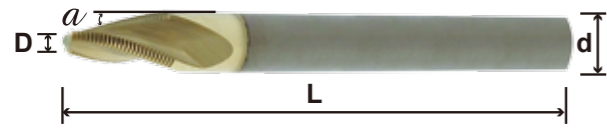

單位：mm (Unit : mm)

產品編號 Model No.	刃徑 D Diameter	牙距 MM Pitch	角度 a Taper	刃長 l Flute Length	刃數 T Teeth	柄徑 d Shank Diameter	全長 L Overall Length	價格 Price	備註
5 VUC 0120300103GR	1.2	0.3	10°	7.90	3T	4	50		
5 VUC 0150300103GR	1.5	0.3	10°	7.04	3T	4	50		
5 VUC 0150375103GR	1.5	0.375	10°	7.04	3T	4	50		
5 VUC 0150330103GR	1.5	0.33	10°	7.04	3T	4	50		
5 VUC 0180430103GR	1.8	0.43	10°	11.90	3T	6	50		
5 VUC 0230400103GR	2.3	0.4	10°	10.46	3T	6	50		
5 VUC 0260400103GR	2.6	0.4	10°	9.60	3T	6	50		
5 VUC 0300333083GR	3	0.333	8°	10.65	3T	6	50		
5 VUC 03004167083GR	3	0.4167	8°	10.65	3T	6	50		

備註：其他規格，請來電洽詢。

適用材質：

★最適合 ●適合 ▲佳

碳素鋼 Carbon steels	合金鋼 Alloy steel	預硬鋼材 Pre-hardened steels	高硬度鋼 High-hardened					不銹鋼 Stainless steels	鈦合金 Titanium alloys	鎳基合金 Nickel Based alloys	銅合金 Copper alloys	鋁合金 Aluminum alloys
		~HRC45	~HRC50	~HRC55	~HRC60	~HRC65						
★	★	★	★	●	●	●	★	●		●	●	

## 2 鎢鋼倒角刀 - 2T

Tungsten Carbide Chamfering End Mill, 2 Flutes



單位：mm (Unit : mm)

產品編號 Model No.	角度 a Top Angle	外徑 D Outside Diameter	刃數 T Flute	柄徑 d Shank Diameter	全長 L Overall Length	價格 Price	備註
2 2R2WC0400902	90°	4	2	4	50		
2 2R2WC0600902	90°	6	2	6	50		
2 2R2WC0800902	90°	8	2	8	60		
2 2R2WC1000902	90°	10	2	10	75		
2 2R2WC1200902	90°	12	2	12	75		
2 2R2WC0401202	120°	4	2	4	50		
2 2R2WC0601202	120°	6	2	6	50		
2 2R2WC0801202	120°	8	2	8	60		
2 2R2WC1001202	120°	10	2	10	75		
2 2R2WC1201202	120°	12	2	12	75		

備註：其他規格，請來電洽詢。

## 2 鎢鋼倒角刀 - 4T

Tungsten Carbide Chamfering End Mill, 4 Flutes



單位：mm (Unit : mm)

產品編號 Model No.	角度 a Top Angle	外徑 D Outside Diameter	小平面 D1 Top Diameter	刃數 T Flute	柄徑 d Shank Diameter	全長 L Overall Length	價格 Price	備註
2 2R2WC0400904	90°	4	0.5	4	4	50		
2 2R2WC0600904	90°	6	0.5	4	6	50		
2 2R2WC0800904	90°	8	0.5	4	8	60		
2 2R2WC1000904	90°	10	1	4	10	75		
2 2R2WC1200904	90°	12	1	4	12	75		

備註：其他規格，請來電洽詢。

適用材質：

★最適合 ●適合 ▲佳

碳素鋼 Carbon steels	合金鋼 Alloy steel	預硬鋼材 Pre-hardened steels	高硬度鋼 High-hardened					不銹鋼 Stainless steels	鈦合金 Titanium alloys	鎳基合金 Nickel Based alloys	銅合金 Copper alloys	鋁合金 Aluminum alloys
		~HRC45	~HRC50	~HRC55	~HRC60	~HRC65						
★	★	★	●	●			★	★		★	★	

## 2 鎢鋼上下倒角刀

Tungsten Carbide Back and Front Chamfering Cutter

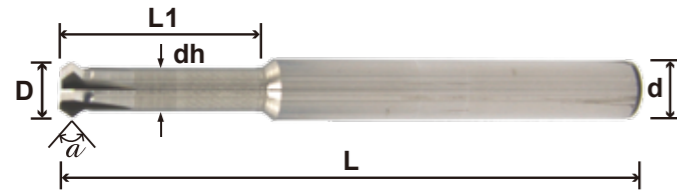

單位：mm (Unit : mm)

產品編號 Model No.	角度 a Top Angle	外徑 D Outside Diameter	頸徑 dh Neck dia	頸長 L1	刃數 T Flute	柄徑 d Shank Diameter	全長 L Overall Length	價格 Price	備註
2 2R2UD0400904D6	90°	4	2	10	4	6	75		
2 2R2UD0600904	90°	6	3	15	4	6	75		
2 2R2UD0800904	90°	8	4	20	4	8	75		
2 2R2UD1000904	90°	10	5	25	4	10	75		
2 2R2UD1200904	90°	12	6	30	4	12	75		

備註：其他規格，請來電洽詢。

適用材質：

★最適合 ●適合 ▲佳

碳素鋼 Carbon steels	合金鋼 Alloy steel	預硬鋼材 Pre-hardened steels		高硬度鋼 High-hardened			不銹鋼 Stainless steels	鈦合金 Titanium alloys	鎳基合金 Nickel Based alloys	銅合金 Copper alloys	鋁合金 Aluminum alloys
		~HRC45	~HRC50	~HRC55	~HRC60	~HRC65					
★	★	●	●	●	▲		★	●	●	★	★

## 2 V2SD 鎢鋼鑽銑刀

Tungsten Carbide V-Pointed End Mill (Drilling and Milling)

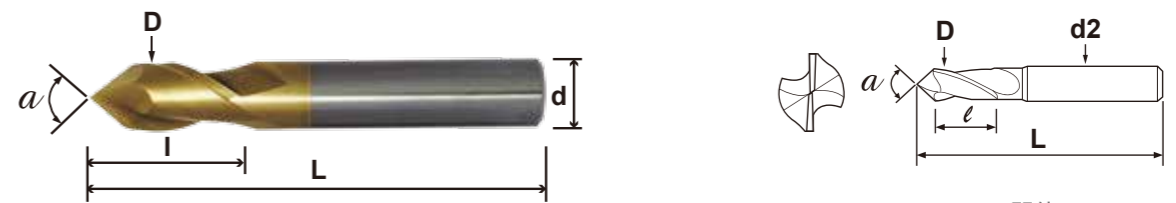

單位：mm (Unit : mm)

產品編號 Model No.	刀徑 D × 角度 a Diameter Top Angle	刃長 l Flute Length	柄徑 d Shank Diameter	全長 L Overall Length	價格 Price	備註
V2 2 SD 0300902TXM	3 × 90°	8	3	50		
V2 2 SD 0400902TXM	4 × 90°	11	4	50		
V2 2 SD 0600902TXM	6 × 90°	15	6	50		
V2 2 SD 0800902TXM	8 × 90°	20	8	60		
V2 2 SD 1000902TXM	10 × 90°	25	10	75		
V2 2 SD 1200902TXM	12 × 90°	30	12	75		
V2 2 SD 1600902TXM	16 × 90°	45	16	100		

產品編號 Model No.	刀徑 D × 角度 a Diameter Top Angle	刃長 l Flute Length	柄徑 d Shank Diameter	全長 L Overall Length	價格 Price	備註
V2 2 SLSD 0300902TXM	3 × 90°	8	3	75		
V2 2 SLSD 0400902TXM	4 × 90°	11	4	75		
V2 2 MLSD 0600902TXM	6 × 90°	15	6	100		
V2 2 MLSD 0800902TXM	8 × 90°	20	8	100		
V2 2 MLSD 1000902TXM	10 × 90°	25	10	100		
V2 2 MLSD 1200902TXM	12 × 90°	30	12	100		
V2 2 LLSLSD 1600902TXM	16 × 90°	45	16	150		

備註：其他規格，請來電洽詢。

適用材質：

★最適合 ●適合 ▲佳

碳素鋼 Carbon steels	合金鋼 Alloy steel	預硬鋼材 Pre-hardened steels		高硬度鋼 High-hardened			不銹鋼 Stainless steels	鈦合金 Titanium alloys	鎳基合金 Nickel Based alloys	銅合金 Copper alloys	鋁合金 Aluminum alloys
		~HRC45	~HRC50	~HRC55	~HRC60	~HRC65					
★	★	●					●	●		★	★

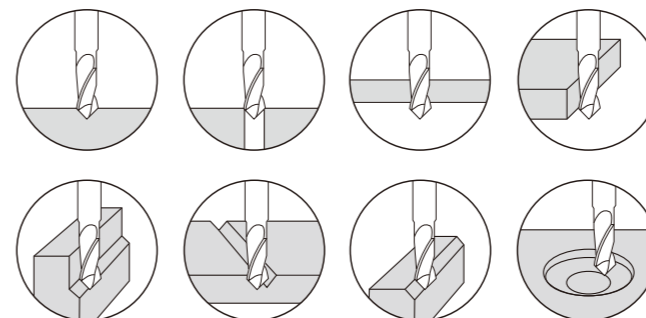

### ② 錫鋼定位鑽 - 2T

Tungsten Carbide Spot Drills.

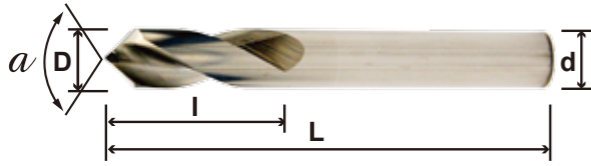

單位：mm (Unit : mm)

產品編號 Model No.	角度 Top Angle $a$	刀徑 Diameter D	刃長 Flute Length l	柄徑 Shank Diameter d	全長 Overall Length L	價格 Price	備註
SDNCWC 090030	90°	3	10	3	50		
SDNCWC 090040	90°	4	12	4	50		
SDNCWC 090050	90°	5	15	5	50		
SDNCWC 090060	90°	6	20	6	50		
SDNCWC 090080	90°	8	25	8	60		
SDNCWC 090100	90°	10	25	10	75		
SDNCWC 090120	90°	12	30	12	75		
SDNCWC 090160	90°	16	35	16	100		
SDNCWC 120030	120°	3	10	3	50		
SDNCWC 120040	120°	4	12	4	50		
SDNCWC 120050	120°	5	15	5	50		
SDNCWC 120060	120°	6	20	6	50		
SDNCWC 120080	120°	8	25	8	60		
SDNCWC 120100	120°	10	25	10	75		
SDNCWC 120120	120°	12	30	12	75		
SDNCWC 120160	120°	16	35	16	100		

備註：其他規格，請來電洽詢。

適用材質：

★最適合 ●適合 ▲佳

碳素鋼 Carbon steels	合金鋼 Alloy steel	預硬鋼材 Pre-hardened steels		高硬度鋼 High-hardened			不銹鋼 Stainless steels	鈦合金 Titanium alloys	鎳基合金 Nickel Based alloys	銅合金 Copper alloys	鋁合金 Aluminum alloys
		~HRC45	~HRC50	~HRC55	~HRC60	~HRC65					
★	★	●	●				★	★	●	★	★

### ⑤ TTA 錫鋼雕刻銑刀

Tungsten Carbide Engraving End Mill.



- 刀尖提供0.1、0.2、0.3、0.4、0.5寬度，讓使用者有更多的選擇。
- 適合加工一般鋼材、鋁合金、銅合金。
- 適合中加工、精加工用。

單位：mm (Unit : mm)

產品編號 Model No.	外徑 Outside Diameter D	錐度 Taper Angle $a$	刃數 Flute T	柄徑 Shank Diameter d	全長 Overall Length L	價格 Price	備註
5 TTA 0011501	0.1	15°	1	4	50		
5 TTA 0021501	0.2	15°	1	4	50		
5 TTA 0031501	0.3	15°	1	4	50		
5 TTA 0041501	0.4	15°	1	4	50		
5 TTA 0051501	0.5	15°	1	4	50		

備註：其他規格，請來電洽詢。

適用材質：

★最適合 ●適合 ▲佳

碳素鋼 Carbon steels	合金鋼 Alloy steel	預硬鋼材 Pre-hardened steels		高硬度鋼 High-hardened			不銹鋼 Stainless steels	鈦合金 Titanium alloys	鎳基合金 Nickel Based alloys	銅合金 Copper alloys	鋁合金 Aluminum alloys
		~HRC45	~HRC50	~HRC55	~HRC60	~HRC65					
★	★	●	●	●			●	●	▲	★	★

### ② RC 錫鋼外R角銑刀

Tungsten Carbide Outer Radius End Mill

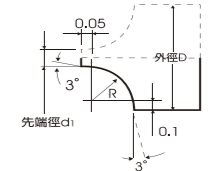

單位：mm (Unit : mm)

產品編號 Model No.	外R角 Radius R	先端徑 Top Diameter d1	外徑 Outside Diameter D	柄徑 Shank Diameter d	全長 Overall Length L	價格 Price	備註
2 RC 0104	0.5R	1.5	2.7	4	50		
2 RC 1504	0.75R	1.5	3.2	4	50		
2 RC 0204	1R	1.5	3.7	4	50		
2 RC 0254D6	1.25R	1.5	4.2	6	50		
2 RC 0304D6	1.5R	1.5	4.7	6	50		
2 RC 0354D6	1.75R	1.5	5.2	6	50		
2 RC 0404D6	2R	1.5	5.7	6	50		
2 RC 0504D8	2.5R	1.5	6.7	8	60		
2 RC 0604D8	3R	1.5	7.7	8	60		
2 RC 0704D10	3.5R	2	9.2	10	75		
2 RC 0804D12	4R	2	10.2	12	75		
2 RC 1004D14	5R	3	13.2	14	100		
2 RC 1204D16	6R	3	15.2	16	100		

備註：其他規格，請來電洽詢。

適用材質：

★最適合 ●適合 ▲佳

碳素鋼 Carbon steels	合金鋼 Alloy steel	預硬鋼材 Pre-hardened steels		高硬度鋼 High-hardened			不銹鋼 Stainless steels	鈦合金 Titanium alloys	鎳基合金 Nickel Based alloys	銅合金 Copper alloys	鋁合金 Aluminum alloys
		~HRC45	~HRC50	~HRC55	~HRC60	~HRC65					
★	★	●	●	●	▲		★	●	●	★	★

### ⑤ 280° 錫鋼棒棒糖球刀

280° Lollipop tungsten Carbide Ball Nose milling cutter.



單位：mm (Unit : mm)

產品編號 Model No.	球頭半徑 Radius R	外徑 D Outside Diameter	頸徑 dh Neck dia	頸長 L1	刃數 Flute T	柄徑 d Shank Diameter	全長 L Overall Length	價格 Price	備註
5 MTB 0102	0.5R	1	0.65	2	2	4	50		
5 MTB 0152	0.75R	1.5	0.98	3	2	4	50		
5 MTB 0202	1R	2	1.3	4	2	4	50		
5 MTB 0302	1.5R	3	1.95	6	2	4	50		
5 MTB 0402	2R	4	2.6	8	2	4	50		
5 TB 0502	2.5R	5	3.25	10	2	6	50		
5 TB 0602	3R	6	3.9	12	2	6	50		
5 TB 0802	4R	8	5.2	16	2	8	75		
5 TB 1002	5R	10	6.5	20	2	10	75		
5 TB 1202	6R	12	7.8	24	2	12	75		

備註：其他規格，請來電洽詢。

適用材質：

★最適合 ●適合 ▲佳

碳素鋼 Carbon steels	合金鋼 Alloy steel	預硬鋼材 Pre-hardened steels		高硬度鋼 High-hardened			不銹鋼 Stainless steels	鈦合金 Titanium alloys	鎳基合金 Nickel Based alloys	銅合金 Copper alloys	鋁合金 Aluminum alloys
		~HRC45	~HRC50	~HRC55	~HRC60	~HRC65					
★	★	●	●	●	▲		★	●	●	★	★

## 638 複合材料、碳纖維專用鎢鋼立銑刀

For Composite Materials, Carbon Fiber tungsten Carbide milling cutter

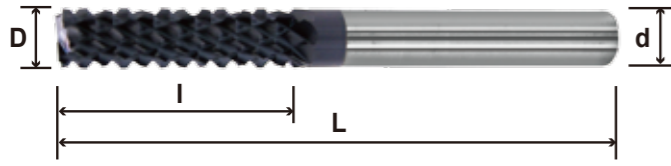

單位 : mm (Unit : mm)

產品編號 Model No.	刃徑 D Diameter	刃長 l Flute Length	柄徑 d Shank Diameter	全長 L Overall Length	單價 price	備註
638 XXE 010N	1	4	4	50		
638 XXE 015N	1.5	6	4	50		
638 XXE 020N	2	8	4	50		
638 XXE 030N	3	12	4	50		
638 XXE 040N	4	16	4	50		
638 XXE 060N	6	24	6	60		
638 XXE 080N	8	32	8	75		
638 XXE 100NS30	10	30	10	75		
638 XXE 100NS50L100	10	50	10	100		
638 XXE 120NS50L100	12	50	12	100		

備註：不是常備庫存品，訂購前請來電洽詢。

適用材質： ★最適合 ●適合 ▲佳

碳素鋼 Carbon steels	合金鋼 Alloy steel	預硬鋼材 Pre-hardened steels ~HRC45	高硬度鋼 High-hardened ~HRC50 ~HRC55 ~HRC60 ~HRC65			碳纖維複材 CFRP	玻璃纖維複材 GFRP	銅合金 Copper alloys	鋁合金 Aluminum alloys
						★	★		

## 638 YY銑刀

YYE For Composite Materials Tungsten Carbide Milling Cutter



單位 : mm (Unit : mm)

產品編號 Model No.	刃徑 D Diameter	刃長 l Flute Length	柄徑 d Shank Diameter	全長 L Overall Length	單價 price	備註
638 YYE 0104N	1	4	4	50		
638 YYE 010N	1.5	6	4	50		
638 YYE 020N	2	8	4	50		
638 YYE 030N	3	12	4	50		
638 YYE 040NS12	4	16	4	50		
638 YYE 060NL60	6	24	6	60		
638 YYE 080NL75	8	32	8	75		
638 YYE 100N	10	30	10	75		
638 YYE 100NS50L100	10	50	10	100		
638 YYE 120NS50	12	50	12	100		

備註：不是常備庫存品，訂購前請來電洽詢。

適用材質： ★最適合 ●適合 ▲佳

碳素鋼 Carbon steels	合金鋼 Alloy steel	預硬鋼材 Pre-hardened steels ~HRC45	高硬度鋼 High-hardened ~HRC50 ~HRC55 ~HRC60 ~HRC65			碳纖維複材 CFRP	玻璃纖維複材 GFRP	銅合金 Copper alloys	鋁合金 Aluminum alloys
★	★					★	★	●	●

## 2 鎢鋼T型銑刀

Tungsten Carbide, T-Shape End Mill, 4 Flutes / 6 Flutes

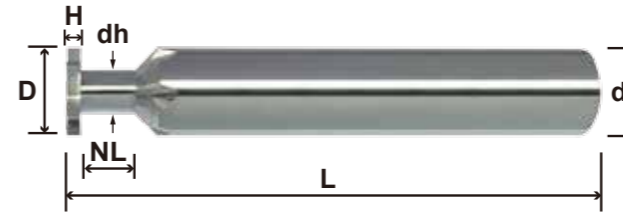

單位 : mm (Unit : mm)

產品編號 Model No.	刃徑 D Diameter	厚度 H	頸徑 dh	頸長 NL	刃數 T	柄徑 d Shank Diameter	全長 L Overall Length	單價 price	備註
2 TE03000504	3	x 0.5	1.5	3	4	4	50		
2 TE03000604	3	x 0.6	1.5	3	4	4	50		
2 TE03000704	3	x 0.7	1.5	3	4	4	50		
2 TE03000804	3	x 0.8	1.5	3	4	4	50		
2 TE03000904	3	x 0.9	1.5	3	4	4	50		
2 TE03001004	3	x 1	1.5	3	4	4	50		
2 TE03001504	3	x 1.5	1.5	3	4	4	50		
2 TE03002004	3	x 2	1.5	3	4	4	50		
2 TE04000504	4	x 0.5	2	3.5	4	4	50		
2 TE04000604	4	x 0.6	2	3.5	4	4	50		
2 TE04000704	4	x 0.7	2	3.5	4	4	50		
2 TE04000804	4	x 0.8	2	3.5	4	4	50		
2 TE04000904	4	x 0.9	2	3.5	4	4	50		
2 TE04001004	4	x 1	2	3.5	4	4	50		
2 TE04001504	4	x 1.5	2	3.5	4	4	50		
2 TE04002004	4	x 2	2	3.5	4	4	50		
2 TE05000506	5	x 0.5	2.5	4	6	6	50		
2 TE05000606	5	x 0.6	2.5	4	6	6	50		
2 TE05000706	5	x 0.7	2.5	4	6	6	50		
2 TE05000806	5	x 0.8	2.5	4	6	6	50		
2 TE05000906	5	x 0.9	2.5	4	6	6	50		
2 TE05001006	5	x 1	2.5	4	6	6	50		
2 TE05001506	5	x 1.5	2.5	4	6	6	50		
2 TE05002006	5	x 2	2.5	4	6	6	50		
2 TE06000506	6	x 0.5	3	4	6	6	50		
2 TE06000606	6	x 0.6	3	4	6	6	50		
2 TE06000706	6	x 0.7	3	4	6	6	50		
2 TE06000806	6	x 0.8	3	4	6	6	50		
2 TE06000906	6	x 0.9	3	4	6	6	50		
2 TE06001006	6	x 1	3	4	6	6	50		
2 TE06001506	6	x 1.5	3	4	6	6	50		
2 TE06002006	6	x 2	3	4	6	6	50		
2 TE08001006	8	x 1	4	4	6	8	60		
2 TE08001506	8	x 1.5	4	4	6	8	60		
2 TE08002006	8	x 2	4	4	6	8	60		
2 TE08002506	8	x 2.5	4	4	6	8	60		
2 TE10001006	10	x 1	5	6	6	10	75		
2 TE10001506	10	x 1.5	5	6	6	10	75		
2 TE10002006	10	x 2	5	6	6	10	75		
2 TE10003006	10	x 3	5	6	6	10	75		
2 TE12001006	12	x 1	6	7	6	12	75		
2 TE12001506	12	x 1.5	6	7	6	12	75		
2 TE12002006	12	x 2	6	7	6	12	75		
2 TE12003006	12	x 3	6	7	6	12	75		

備註：其他規格，請來電洽詢。

適用材質： ★最適合 ●適合 ▲佳

碳素鋼 Carbon steels	合金鋼 Alloy steel	預硬鋼材 Pre-hardened steels ~HRC45	高硬度鋼 High-hardened ~HRC50 ~HRC55 ~HRC60 ~HRC65			不銹鋼 Stainless steels	鈦合金 Titanium alloys	鎳基合金 Nickel Based alloys	銅合金 Copper alloys	鋁合金 Aluminum alloys
★	★					★	●		★	★

## 焊刃鎢鋼T型槽銑刀(直刃)

Brazed Carbide T-Slot Cutter (Straight Flute)

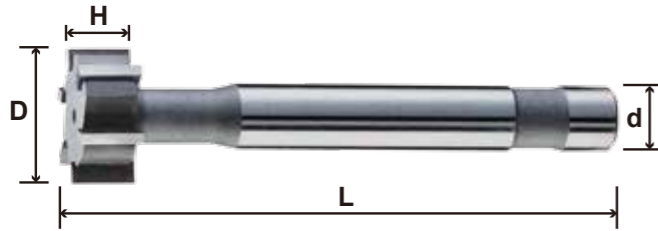

單位：mm (Unit : mm)

產品編號 Model No.	刃徑 D	厚度 H	刃數 T	柄徑 d	全長 L	單價 price	備註
CBTE 2000206	20	2 ~ 10mm	4	12	100		
CBTE 2500206	25	2 ~ 10mm	6	12	100		
CBTE 3000206	30	2 ~ 10mm	6	16	100		
CBTE 3500206	35	2 ~ 10mm	6	16	100		
CBTE 4000206	40	2 ~ 10mm	6	16	100		
CBTE 4500206	45	2 ~ 10mm	6	20	100		
CBTE 5000208	50	2 ~ 10mm	8	20	100		
CBTE 6000210	60	2 ~ 5 mm	10	20	120		
CBTE 7500216	75	2 ~ 5 mm	12	25	120		

備註：其他規格，請來電洽詢。

適用材質：

★最適合 ●適合 ▲佳

碳素鋼 Carbon steels	合金鋼 Alloy steel	預硬鋼材	高硬度鋼					不銹鋼 Stainless steels	鈦合金 Titanium alloys	鎳基合金 Nickel Based alloys	銅合金 Copper alloys	鋁合金 Aluminum alloys
		Pre-hardened steels	High-hardened									
		~HRC45	~HRC50	~HRC55	~HRC60	~HRC65						
★	★	●	●				★	●		★	★	

## 鎢鋼鳩尾銑刀 45°/60°

Carbide Dove-Tail End Mills

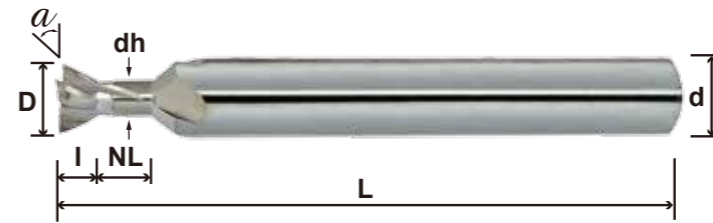

單位：mm (Unit : mm)

產品編號 Model No.	刃徑 D	角度 a	刃長 l	頸徑 dh	頸長 NL	刃數 T	柄徑 d	全長 L	單價 price	備註
2 RJ 030454D6	3	45°	0.8	1.4	3	4	6	60		
2 RJ 040454	4	45°	1	2	3	4	4	50		
2 RJ 040454D6	4	45°	1	2	3	4	6	60		
2 RJ 050454	5	45°	1.2	2.5	4	4	6	60		
2 RJ 060454	6	45°	1.4	3	4	4	6	60		
2 RJ 080454	8	45°	1.9	4	5	4	8	60		
2 RJ 100454	10	45°	2.4	5	6	4	10	75		
2 RJ 120454	12	45°	2.9	6	7	4	12	75		

單位：mm (Unit : mm)

產品編號 Model No.	刃徑 D	角度 a	刃長 l	頸徑 dh	頸長 NL	刃數 T	柄徑 d	全長 L	單價 price	備註
2 RJ 030604D6	3	60°	1.2	1.5	3	4	6	60		
2 RJ 040604D6	4	60°	1.6	2	3.5	4	6	60		
2 RJ 050604	5	60°	2.2	2.3	4	4	6	60		
2 RJ 060604	6	60°	2.7	2.7	4	4	6	60		
2 RJ 080604	8	60°	3.7	3.6	5	4	8	60		
2 RJ 100604	10	60°	4.6	4.5	6	4	10	75		
2 RJ 120604	12	60°	5.6	5.4	7	4	12	75		

備註：其他規格，請來電洽詢。

適用材質：

★最適合 ●適合 ▲佳

碳素鋼 Carbon steels	合金鋼 Alloy steel	預硬鋼材	高硬度鋼					不銹鋼 Stainless steels	鈦合金 Titanium alloys	鎳基合金 Nickel Based alloys	銅合金 Copper alloys	鋁合金 Aluminum alloys
		Pre-hardened steels	High-hardened									
		~HRC45	~HRC50	~HRC55	~HRC60	~HRC65						
★	★	●					★	●		★	★	

5 TTA 鎢鋼斜度銑刀



Tungsten Carbide Taper End Mills-2 / 4 Flutes

- 排屑順暢，刀具壽命佳，精度佳。  
Chip removal fluency, Great tool life, Excellent precision.
- 成型工件一次加工完成，減少加工時間及成本。  
Formed workpiece-finish in one time, reduce the processing time and cost.
- 適合加工一般鋼材、不銹鋼、模具鋼。  
Suitable: Alloy Steel, Stainless Steel, Die Steel.

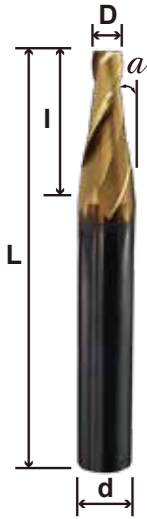

單位：mm (Unit : mm)

產品編號 Model No.	外徑 D Outside Diameter	角度 a Taper Angle	刃長 l Flute Length	刃數 T Flute	柄徑 d Shank Diameter	全長 L Overall Length	價格 price	備註
5 TTA 0050102OL	0.5	1°	2	2	4	50		
5 TTA 0050252OL	0.5	2.5°	2	2	4	50		
5 TTA 0050702OL	0.5	7°	2	2	4	50		
5 TTA 0051002OL	0.5	10°	2	2	4	50		
5 TTA 0080052OL	0.8	0.5°	3	2	4	50		
5 TTA 0080102OL	0.8	1°	3	2	4	50		
5 TTA 0080152OL	0.8	1.5°	3	2	4	50		
5 TTA 0080202OL	0.8	2°	3	2	4	50		
5 TTA 0080252OL	0.8	2.5°	3	2	4	50		
5 TTA 0080302OL	0.8	3°	3	2	4	50		
5 TTA 0080502OL	0.8	5°	3	2	4	50		
5 TTA 0080702OL	0.8	7°	3	2	4	50		
5 TTA 0081002OL	0.8	10°	3	2	4	50		
5 TTA 0100052TX	1	0.5°	4	2	4	50		
5 TTA 0100102TX	1	1°	4	2	4	50		
5 TTA 0100152TX	1	1.5°	4	2	4	50		
5 TTA 0100202TX	1	2°	4	2	4	50		
5 TTA 0100302TX	1	3°	4	2	4	50		
5 TTA 0100502TX	1	5°	4	2	4	50		
5 TTA 0100702TX	1	7°	4	2	4	50		
5 TTA 0101402TX	1	14°	4	2	4	50		
5 TTA 0101502TX	1	15°	4	2	4	50		
5 TTA 0150052TX	1.5	0.5°	5	2	4	50		
5 TTA 0150102TX	1.5	1°	5	2	4	50		
5 TTA 0150152TX	1.5	1.5°	5	2	4	50		
5 TTA 0150202TX	1.5	2°	5	2	4	50		
5 TTA 0150302TX	1.5	3°	5	2	4	50		
5 TTA 0150502TX	1.5	5°	5	2	4	50		
5 TTA 0150702TX	1.5	7°	5	2	4	50		
5 TTA 0151002TX	1.5	10°	5	2	4	50		
5 TTA 0152002TXD6	1.5	20°	6.18	2	6	50		
5 TTA 0200052TX	2	0.5°	6	2	4	50		
5 TTA 0200102TX	2	1°	6	2	4	50		
5 TTA 0200152TX	2	1.5°	6	2	4	50		
5 TTA 0200202TX	2	2°	6	2	4	50		
5 TTA 0200302TX	2	3°	6	2	4	50		
5 TTA 0200502TX	2	5°	6	2	4	50		
5 TTA 0200702TX	2	7°	6	2	4	50		
5 TTA 0201002TX	2	10°	6	2	4	50		
5 TTA 0201502TXD6	2	15°	6	2	6	50		

單位：mm (Unit : mm)

產品編號 Model No.	外徑 D Outside Diameter	角度 a Taper Angle	刃長 l Flute Length	刃數 T Flute	柄徑 d Shank Diameter	全長 L Overall Length	價格 price	備註
5 TTA 0250052TX	2.5	0.5°	8	2	4	50		
5 TTA 0250102TX	2.5	1°	8	2	4	50		
5 TTA 0250152TX	2.5	1.5°	8	2	4	50		
5 TTA 0250202TX	2.5	2°	8	2	4	50		
5 TTA 0250252TX	2.5	2.5°	8	2	4	50		
5 TTA 0250302TX	2.5	3°	8	2	4	50		
5 TTA 0250502TXD6	2.5	5°	8	2	6	50		
5 TTA 0250702TXD6	2.5	7°	8	2	6	50		
5 TTA 0251002TXD6	2.5	10°	8	2	6	50		
5 TTA 0300054TX	3	0.5°	10	4	6	50		
5 TTA 0300104TX	3	1°	10	4	6	50		
5 TTA 0300154TX	3	1.5°	10	4	6	50		
5 TTA 0300204TX	3	2°	10	4	6	50		
5 TTA 0300254TX	3	2.5°	10	4	6	50		
5 TTA 0300304TX	3	3°	10	4	6	50		
5 TTA 0300504TX	3	5°	10	4	6	50		
5 TTA 0300704TX	3	7°	10	4	6	50		
5 TTA 0400054TX	4	0.5°	15	4	6	50		
5 TTA 0400104TX	4	1°	15	4	6	50		
5 TTA 0400154TX	4	1.5°	15	4	6	50		
5 TTA 0400204TX	4	2°	15	4	6	50		
5 TTA 0400254TX	4	2.5°	15	4	6	50		
5 TTA 0400304TX	4	3°	15	4	6	50		
5 TTA 0400504TXD8	4	5°	15	4	8	60		
5 TTA 0400504TX	4	5°	15	4	6	50		
5 TTA 0400604TX	4	6°	15	4	6	50		
5 TTA 0400704TXD8	4	7°	15	4	8	60		
5 TTA 0500104TX	5	1°	20	4	6	60		
5 TTA 0500154TX	5	1.5°	20	4	8	60		
5 TTA 0500204TX	5	2°	20	4	8	60		
5 TTA 0500254TX	5	2.5°	20	4	8	60		
5 TTA 0500304TX	5	3°	20	4	8	60		
5 TTA 0500504TX	5	5°	20	4	8	60		
5 TTA 0600054TX	6	0.5°	20	4	8	60		
5 TTA 0600154TX	6	1.5°	20	4	8	60		
5 TTA 0600204TX	6	2°	20	4	8	60		
5 TTA 0600254TX	6	2.5°	20	4	8	60		
5 TTA 0600304TX	6	3°	20	4	8	60		
5 TTA 0600504TX	6	5°	20	4	10	75		

備註：其他規格，請來電洽詢。

適用材質：

★最適 適合 ▲佳

碳素鋼 Carbon steels	合金鋼 Alloy steel	預硬鋼材 Pre-hardened steels		高硬度鋼 High-hardened					不銹鋼 Stainless steels	鈦合金 Titanium alloys	鎳基合金 Nickel Based alloys	銅合金 Copper alloys	鋁合金 Aluminum alloys
		~HRC45	~HRC50	~HRC55	~HRC60	~HRC65							
★	★	★										★	★

## ▶ WH系列陶瓷尋邊器

特性 韌性強 耐磨損 硬度高 不導磁 不生鏽 壽命長

WH-1010



WH-1020

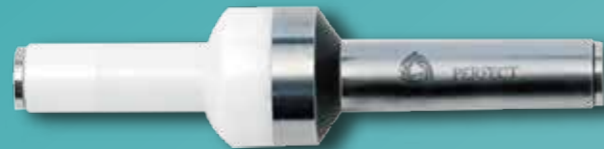

WH-P1



WH-P2



WH-420L



## ▶ Z軸設定器系列

NZH-50



NZM-50



NZD-100



型號	有.無磁	說明
NZH-50	有磁/無磁	尺寸63x50mm
NZM-50	有磁/無磁	尺寸48x50mm
NZD-100	無磁	尺寸57x50x100mm

錫鋼抗震刀柄



鎖牙式刀把



SE90AP10銑刀頭



TE90AX06銑刀頭



TE90AX09銑刀頭



RT0702銑刀頭



RT1003銑刀頭



日立AJU鑽銑刀頭



CC0602銑刀頭



三菱APMT1135銑刀頭



三菱APMT1604銑刀頭



三菱AOMT1236銑刀頭



RD0501銑刀頭



RD0702銑刀頭



RD1003銑刀頭



RP1003銑刀頭



SE90AX12銑刀頭



EP0603銑刀頭



日立RD10T3銑刀頭



WGR精修刀頭



PPH精修刀頭



RD0501鎢鋼快削刀頭



RD0501銑刀頭



HESD銑刀頭



HSB銑刀頭



HESR銑刀頭



HAE銑刀頭



HACB銑刀頭



HAR銑刀頭



H2R2倒角刀頭



HMHR粗銑刀頭



HRC外角刀頭

### 錫鋼抗震刀柄優點

1. 使用高級碳化錳材質製成，剛性優異、吸震性佳，不會因橫向鑽力過大，而扭曲變形。
2. 延長加工深度，提升加工面精度，實現超長、超深、超高精度加工之可行性。
3. 沒有焊接處斷裂之虞，強調刀頭之多變化性。縱使刀頭損壞，立即更換即可上線。

\* 產品豐富，其他規格請洽詢..



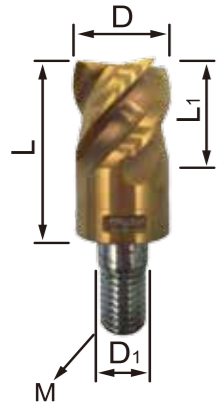

單位：mm (Unit : mm)

產品編號 Model No.	D 直徑 Diameter	L1 刃長 Flute-Length	L 刀頭全長 Overall Length	D1 支撐位頸徑 Neck Diameter	M 連接螺紋 Tread Size	備註
HESD 0804TX	8	8	17	5.5	M05	
HESD 1004TX	10	10	21	5.5	M05	
HESD 1204TX	12	12	25.5	6.5	M06	
HESD 1604TX	16	16	30	8.5	M08	
HESD 2004TX	20	20	38	10.5	M10	
HESD 2504TX	25	25	42	12.5	M12	

備註：其它規格，請來電洽詢。

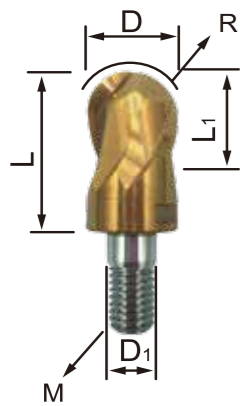

單位：mm (Unit : mm)

產品編號 Model No.	R 球頭半徑 Radius	L1 刃長 Flute-Length	L 刀頭全長 Overall Length	D1 支撐位頸徑 Neck Diameter	M 連接螺紋 Tread Size	備註
HSB 0802TX	4R	8	17	5.5	M05	
HSB 1002TX	5R	10	21	5.5	M05	
HSB 1202TX	6R	12	25.5	6.5	M06	
HSB 1602TX	8R	16	30	8.5	M08	
HSB 2002TX	10R	20	38	10.5	M10	
HSB 2502TX	12.5R	25	42	12.5	M12	

備註：其它規格，請來電洽詢。

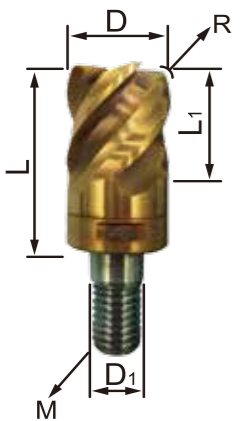

單位：mm (Unit : mm)

產品編號 Model No.	D 直徑 × R 角 Corner Diameter × Radius	L1 刃長 Flute-Length	L 刀頭全長 Overall Length	D1 支撐位頸徑 Neck Diameter	M 連接螺紋 Tread Size	備註
HESR 080054TX	8 × 0.5R	8	17	5.5	M05	
HESR 080104TX	8 × 1R	8	17	5.5	M05	
HESR 100054TX	10 × 0.5R	10	21	5.5	M05	
HESR 100104TX	10 × 1R	10	21	5.5	M05	
HESR 100204TX	10 × 2R	10	21	5.5	M05	
HESR 120054TX	12 × 0.5R	12	25.5	6.5	M06	
HESR 120104TX	12 × 1R	12	25.5	6.5	M06	
HESR 120204TX	12 × 2R	12	25.5	6.5	M06	
HESR 160104TX	16 × 1R	16	30	8.5	M08	
HESR 160204TX	16 × 2R	16	30	8.5	M08	
HESR 200104TX	20 × 1R	20	38	10.5	M10	
HESR 200204TX	20 × 2R	20	38	10.5	M10	
HESR 200304TX	20 × 3R	20	38	10.5	M10	
HESR 250104TX	25 × 1R	25	42	12.5	M12	
HESR 250204TX	25 × 2R	25	42	12.5	M12	
HESR 250304TX	25 × 3R	25	42	12.5	M12	

備註：其它規格，請來電洽詢。

適用材質：

★最適合 ●適合 ▲佳

碳素鋼 Carbon steels	合金鋼 Alloy steel	預硬鋼材 Pre-hardened steels		高硬度鋼 High-hardened				不銹鋼 Stainless steels	鈦合金 Titanium alloys	鎳基合金 Nickel Based alloys	銅合金 Copper alloys	鋁合金 Aluminum alloys
		~HRC45	~HRC50	~HRC55	~HRC60	~HRC65						
●	●	★	★	★	★	★	▲	▲			●	★



單位：mm (Unit : mm)

產品編號 Model No.	D 直徑 Diameter	L1 刃長 Flute-Length	L 刀頭全長 Overall Length	D1 支撐位頸徑 Neck Diameter	M 連接螺紋 Tread Size	備註
HAE 0803	8	8	17	5.5	M05	
HAE 1003	10	10	21	5.5	M05	
HAE 1203	12	12	25.5	6.5	M06	
HAE 1603	16	16	30	8.5	M08	
HAE 2003	20	20	38	10.5	M10	
HAE 2503	25	25	42	12.5	M12	

備註：其它規格，請來電洽詢。



單位：mm (Unit : mm)

產品編號 Model No.	R 球頭半徑 Radius	L1 刃長 Flute-Length	L 刀頭全長 Overall Length	D1 支撐位頸徑 Neck Diameter	M 連接螺紋 Tread Size	備註
HACB 0802	4R	8	17	5.5	M05	
HACB 1002	5R	10	21	5.5	M05	
HACB 1202	6R	12	25.5	6.5	M06	
HACB 1602	8R	16	30	8.5	M08	
HACB 2002	10R	20	38	10.5	M10	
HACB 2502	12.5R	25	42	12.5	M12	

備註：其它規格，請來電洽詢。



單位：mm (Unit : mm)

產品編號 Model No.	D 直徑 × R 角 Corner Diameter × Radius	L1 刃長 Flute-Length	L 刀頭全長 Overall Length	D1 支撐位頸徑 Neck Diameter	M 連接螺紋 Tread Size	備註
HAR 100103	10 × 1R	10	21	5.5	M05	
HAR 100203	10 × 2R	10	21	5.5	M05	
HAR 100303	10 × 3R	10	21	5.5	M05	
HAR 120103	12 × 1R	12	25.5	6.5	M06	
HAR 120153	12 × 1.5R	12	25.5	6.5	M06	
HAR 120203	12 × 2R	12	25.5	6.5	M06	
HAR 120303	12 × 3R	12	25.5	6.5	M06	
HAR 160103	16 × 1R	16	30	8.5	M08	
HAR 160153	16 × 1.5R	16	30	8.5	M08	
HAR 160203	16 × 2R	16	30	8.5	M08	
HAR 160303	16 × 3R	16	30	8.5	M08	
HAR 200203	20 × 2R	20	38	10.5	M10	
HAR 200303	20 × 3R	20	38	10.5	M10	
HAR 200503	20 × 5R	20	38	10.5	M10	
HAR 250203	25 × 2R	25	42	12.5	M12	
HAR 250303	25 × 3R	25	42	12.5	M12	
HAR 250503	25 × 5R	25	42	12.5	M12	

備註：其它規格，請來電洽詢。

適用材質：

★最適合 ●適合 ▲佳

碳素鋼 Carbon steels	合金鋼 Alloy steel	預硬鋼材 Pre-hardened steels		高硬度鋼 High-hardened				不銹鋼 Stainless steels	鈦合金 Titanium alloys	鎳基合金 Nickel Based alloys	銅合金 Copper alloys	鋁合金 Aluminum alloys
		~HRC45	~HRC50	~HRC55	~HRC60	~HRC65						
		★	★	★	★	★	▲	▲			●	★

## GL 鎢鋼抗震刀柄

GL Tungsten Carbide Anti-Vibration Tools Holder

1. 使用全碳化鎢材質製成，剛性優異、吸震性佳、不會因橫向靖力過大，而扭曲變形。  
One piece formed design of the Tungsten Carbide Tools holder, have excellent Stiffness and great Anti-Vibration, will not be twisted and deformed due to excessive lateral force.
2. 延長加工深度，提升加工面精度，實現超長、超深、超高精度加工之可行性。  
Stretch the depth processing, improve the precision of the surface. Achieve the ultra-long, ultra-deep, and ultra-high-precision machining.
3. 沒有焊接斷裂之虞慮，強調刀頭之多變化性。縱使刀頭損壞，立即更換即上線。  
Have no issue of the welding breakage. Emphasize the variability of the exchangeable endmill heads, even the exchangeable endmill head damaged, it can be replaced immediately.

產品編號 Model No.	Fig	L	M	D2	D	D1	L1	a°	備註
GL06-06-060-M03	1	60	M3*0.5	3.5	6	6			
GL06-06-120-M03	1	120	M3*0.5	3.5	6	6			
GL08-08-060-M04	1	60	M4*0.7	4.5	8	8			
GL08-08-100-M04	1	100	M4*0.7	4.5	8	8			
GL08-08-120-M04	1	120	M4*0.7	4.5	8	8			
GL08-10-150-M04-DT60	2	150	M4*0.7	4.5	10	7.8	60	1°	
GL08-08-075-M05	1	75	M5*0.8	5.5	8	8			
GL08-08-100-M05	1	100	M5*0.8	5.5	8	8			
GL08-08-120-M05	1	120	M5*0.8	5.5	8	8			
GL10-10-075-M05	1	75	M5*0.8	5.5	10	10			
GL10-10-100-M05	1	100	M5*0.8	5.5	10	10			
GL10-10-150-M05	1	150	M5*0.8	5.5	10	10			
GL10-12-150-M05-DT60	2	150	M5*0.8	5.5	12	9.8	60	1°	
GL10-20-300-M05-DT135	2	300	M5*0.8	5.5	20	9.8	135	2.15°	
GL12-12-075-M06	1	75	M6*1.0	6.5	12	12			
GL12-12-100-M06	1	100	M6*1.0	6.5	12	12			
GL12-12-150-M06	1	150	M6*1.0	6.5	12	12			
GL12-12-200-M06	1	200	M6*1.0	6.5	12	12			
GL12-16-150-M06-DT70	2	150	M6*1.0	6.5	16	11.8	70	1.65°	
GL12-16-200-M06-DT90	2	200	M6*1.0	6.5	16	11.8	90	1.3°	
GL12-16-250-M06-DT115	2	250	M6*1.0	6.5	16	11.8	115	1°	
GL12-20-300-M06-DT135	2	300	M6*1.0	6.5	20	11.8	135	1.7°	
GL16-16-100-M08	1	100	M8*1.25	8.5	16	16			
GL16-16-150-M08	1	150	M8*1.25	8.5	16	16			
GL16-16-200-M08	1	200	M8*1.25	8.5	16	16			
GL16-16-250-M08	1	250	M8*1.25	8.5	16	16			
GL16-20-200-M08-DT90	2	200	M8*1.25	8.5	20	15.5	90	1.3°	
GL16-20-250-M08-DT115	2	250	M8*1.25	8.5	20	15.5	115	1°	
GL16-20-300-M08-DT135	2	300	M8*1.25	8.5	20	15.5	135	0.85°	
GL20-20-100-M10	1	100	M10*1.5	10.5	20	20			
GL20-20-150-M10	1	150	M10*1.5	10.5	20	20			
GL20-20-200-M10	1	200	M10*1.5	10.5	20	20			
GL20-20-250-M10	1	250	M10*1.5	10.5	20	20			
GL20-20-300-M10	1	300	M10*1.5	10.5	20	20			
GL20-20-400-M10	1	400	M10*1.5	10.5	20	20			
GL20-25-200-M10-DT90	2	200	M10*1.5	10.5	25	19.8	90	1.6°	
GL20-25-250-M10-DT115	2	250	M10*1.5	10.5	25	19.8	115	1.25°	
GL20-25-300-M10-DT135	2	300	M10*1.5	10.5	25	19.8	135	1.1°	

備註：不是常備庫存品，訂購前請來電洽詢。

模  
具  
三  
寶

THREE TREASURES FOR MOLD

模  
具  
三  
寶

THREE TREASURES FOR MOLD

產品編號 Model No.	Fig	L	M	D2	D	D1	L1	a°	備註
GL25-25-100-M12	1	100	M12*1.75	12.5	25	25			
GL25-25-150-M12	1	150	M12*1.75	12.5	25	25			
GL25-25-200-M12	1	200	M12*1.75	12.5	25	25			
GL25-25-250-M12	1	250	M12*1.75	12.5	25	25			
GL25-25-300-M12	1	300	M12*1.75	12.5	25	25			
GL25-25-350-M12	1	350	M12*1.75	12.5	25	25			
GL25-32-200-M12-DT90	2	200	M12*1.75	12.5	32	24.5	90	2.3°	
GL25-32-250-M12-DT115	2	250	M12*1.75	12.5	32	24.5	115	1.75°	
GL25-32-300-M12-DT135	2	300	M12*1.75	12.5	32	24.5	135	1.5°	
GL32-32-150-M16	1	150	M16*2.0	17	32	32			
GL32-32-200-M16	1	200	M16*2.0	17	32	32			
GL32-32-250-M16	1	250	M16*2.0	17	32	32			
GL32-32-300-M16	1	300	M16*2.0	17	32	32			
GL32-32-400-M16	1	400	M16*2.0	17	32	32			
GL42-42-250-M20	1	250	M20*2.5	21	42	42			
GL42-42-300-M20	1	300	M20*2.5	21	42	42			
GL42-42-400-M20	1	400	M20*2.5	21	42	42			
GL42-42-500-M20	1	500	M20*2.5	21	42	42			

備註：不是常備庫存品，訂購前請來電洽詢。

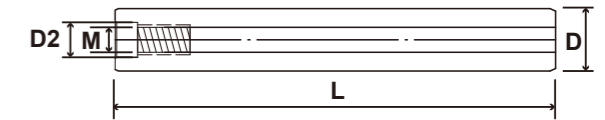

Fig 1

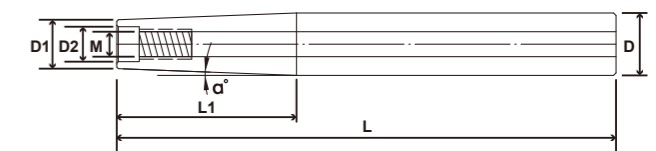

Fig 2

# HD.MIT

## GL Tungsten Carbide Anti-Vibration Tools Holder



### 以生產效率 帶動節能減碳

因為堅持。看到希望

快速 ▶ 節能 ▶ 效率 ▶ 耐用

### 一桿多用替換快速 (成本更低)

- Made of high quality Tungsten Carbide.
- Keep the cost down of the cutting tools.
- Ultra-long, Ultra-deep, and Ultra-high-precision process.

### 抗震效果佳 裝卸方便



# HDC / HUC 錫鋼後拉刀桿

## Tungsten Carbide Toolholder-HDC/HUC Collet Chuck

快速 ▶ 節能 ▶ 效率 ▶ 耐用

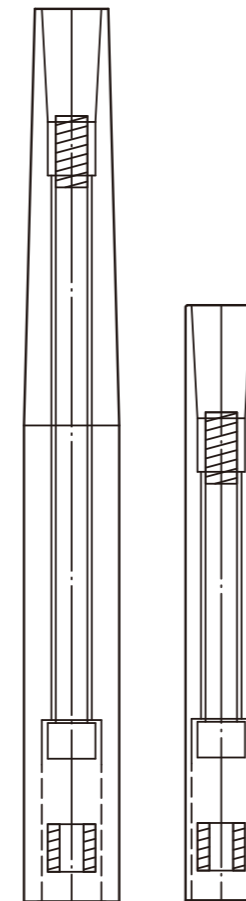

**優異  
剛度**

Excellent  
Stiffness

**振動  
吸收**

Vibration  
absorption

**延長  
刀具壽命**

Increase tools  
service life



1. 使用高級碳化錫材質製成。  
Made of high quality Tungsten Carbide.
2. 超長、超深、超高精度工藝。  
Ultra-long, Ultra-deep, and Ultra-high-precision process.
3. 降低刀具成本。  
Keep the cost down of the cutting tools.

# HD.MIT



## Tungsten Carbide

## HDC/HUC 鎢鋼後拉刀桿

Tungsten Carbide Tools Holder-HDC/HUC Collect Chuck

1. 使用高級碳化鎢材質製成，剛性優異、吸震性佳。  
Made of high quality Tungsten Carbide, have excellent Stiffness and great Anti-Vibration.
2. 延長加工深度，提升加工面精度，實現超長、超深、超高精度加工之可行性。  
Stretch the depth processing, improve the precision of the surface. Achieve the ultra-long, ultra-deep, and ultra-high-precision machining.
3. 降低刀具成本，延長刀具壽命。  
Keep the cost down of the cutting tools, reducing production costs.

產品編號 Model No.	L	L1	D	D1	a°	Fig	備註
HDC4-08-C08-100L	100		8	8		1	
HDC4-10-C10-100L	100		10	10		1	
HDC4-10-C10-150L	150		10	10		1	
HDC4-10-C12-150L-DT60	150	60	12	10	1°	2	
HDC4-10-C16-200L-DT100	200	100	16	10	1.8°	2	
HDC6-12-C12-100L	100		12	12		1	
HDC6-12-C12-150L	150		12	12		1	
HDC6-12.8-C16-150L-DT60	150	60	16	12.8	1.7°	2	
HDC6-12.8-C16-200L-DT90	200	90	16	12.8	1.2°	2	
HDC6-12.8-C20-250L-DT110	250	110	20	12.8	1.9°	2	
HDC6L-12-C12-100L	100		12	12		1	
HDC6L-12-C12-150L	150		12	12		1	
HDC6L-12.8-C16-150L-DT60	150	60	16	12.8	1.7°	2	
HDC6L-12.8-C16-200L-DT90	200	90	16	12.8	1.2°	2	
HDC6L-12.8-C20-250L-DT110	250	110	20	12.8	1.9°	2	
HUC8-16-C16-120L	120		16	16		1	
HUC8-16-C16-150L	150		16	16		1	
HUC8-16-C16-200L	200		16	16		1	
HUC8-16-C20-200L-DT80	200	80	20	16	1.5°	2	
HUC8-16-C20-250L-DT100	250	100	20	16	1.2°	2	
HUC10-20-C20-150L	150		20	20		1	
HUC10-20-C20-200L	200		20	20		1	
HUC10-20-C20-250L	250		20	20		1	
HUC10-23-C25-250L-DT120	250	120	25	23	0.5°	2	
HUC10-23-C25-300L-DT120	300	120	25	23	0.5°	2	

備註：不是常備庫存品，訂購前請來電洽詢。

剛性優異  
吸震性佳



Fig 1

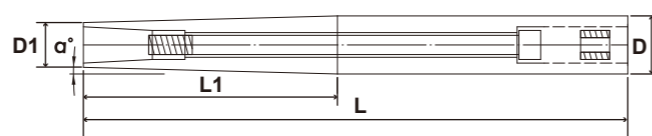

Fig 2

## HDC/HUC 後拉筒夾

HDC/HUC Collet Chuck

產品編號 Model No.	Collet	L	D	∅d	Fig	備註
HDC4-3	HDC4	31	7	3	1	
HDC4-4	HDC4	31	7	4	1	
HDC6-3	HDC6	36	9.6	3	1	
HDC6-3.175	HDC6	36	9.6	3.175	1	
HDC6-4	HDC6	36	9.6	4	1	
HDC6-5	HDC6	36	9.6	5	1	
HDC6-6	HDC6	36	9.6	6	1	
HDCL6-3	HDCL6	60	9.6	3	2	
HDCL6-4	HDCL6	60	9.6	4	2	
HDCL6-5	HDCL6	60	9.6	5	2	
HDCL6-6	HDCL6	60	9.6	6	2	
HUC8-3	HUC8	46.2	12	3	3	
HUC8-4	HUC8	46.2	12	4	3	
HUC8-6	HUC8	46.2	12	6	3	
HUC8-8	HUC8	46.2	12	8	3	
HUC10-3	HUC10	56.5	15	3	3	
HUC10-4	HUC10	56.5	15	4	3	
HUC10-6	HUC10	56.5	15	6	3	
HUC10-8	HUC10	56.5	15	8	3	
HUC10-10	HUC10	56.5	15	10	3	

備註：不是常備庫存品，訂購前請來電洽詢。

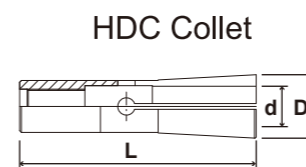

Fig 1

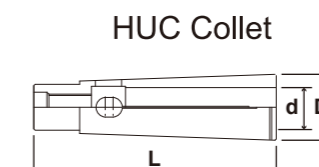

Fig 3

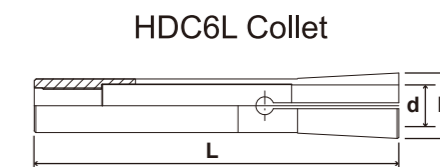
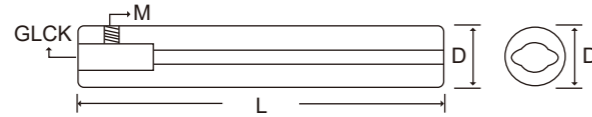

Fig 2

## GLCK 鎢鋼抗震搪刀柄

GLCK Tungsten Carbide Anti-Vibration Boring System Tool Holder

1. 使用全碳化鎢材質製成，沒有焊接斷裂之虞慮，剛性優異、吸震性佳。  
One piece formed design of the Tungsten Carbide Tools holder, will have no issue of the welding breakage, also have excellent Stiffness and great Anti-Vibration.
2. 延長加工深度，提升搪孔加工面精度，實現超長、超深、超高精度加工之可行性。  
Stretch the depth processing, improve the precision of the surface.  
Achieve the ultra-long, ultra-deep, and ultra-high-precision machining.



※可搭配BIG.ACROW.AW搪孔頭使用※

Boring head suggest brand: BIG, AW, ACROW



鎢鋼抗震搪刀柄  
GLCK TOOLHOLDER

產品編號 Model No.	L	D	GLCK	M	備註
GLCK1-19-150L	150	19	GLCK1	4	
GLCK1-19-200L	200	19	GLCK1	4	
GLCK1-19-250L	250	19	GLCK1	4	
GLCK1-20-150L	150	20	GLCK1	4	
GLCK1-20-200L	200	20	GLCK1	4	
GLCK1-20-250L	250	20	GLCK1	4	
GLCK2-24-200L	200	24	GLCK2	5	
GLCK2-24-250L	250	24	GLCK2	5	
GLCK2-24-300L	300	24	GLCK2	5	
GLCK2-25-200L	200	25	GLCK2	5	
GLCK2-25-250L	250	25	GLCK2	5	
GLCK2-25-300L	300	25	GLCK2	5	
GLCK3-31-250L	250	31	GLCK3	6	
GLCK3-31-300L	300	31	GLCK3	6	
GLCK3-31-350L	350	31	GLCK3	6	
GLCK3-31-400L	400	31	GLCK3	6	
GLCK3-32-250L	250	32	GLCK3	6	
GLCK3-32-300L	300	32	GLCK3	6	
GLCK3-32-350L	350	32	GLCK3	6	
GLCK3-32-400L	400	32	GLCK3	6	
GLCK4-42-250L	250	42	GLCK4	8	★
GLCK4-42-300L	300	42	GLCK4	8	★
GLCK4-42-400L	400	42	GLCK4	8	★
GLCK4-42-500L	500	42	GLCK4	8	★

備註：不是常備庫存品，訂購前請來電洽詢。

BORING HEAD & PART  
搪孔刀頭  
配件

產品編號 Model No.	Dimensions.mm					Shape	Insert	Screw	Wrench
	D	H	L	M	Range				
BE09A	9	7	18	M05	9~10.5	搪孔頭 BORING CUTTER HEAD 	TP..0802..	MS2205A	ETF07
BE10.5A	10.5	7	18	M05	10.5~12				
BE12A	12	8	23	M06	12~14				
BE14A	14	10	23	M06	14~16				
BE16A	16	10	23	M06	16~18				
BE18A	18	14	27	M10	18~20				
BE20A	20	14	27	M10	20~22				
BE22A	22	14	27	M10	22~24				
BE24A	24	14	27	M10	24~26				
BE26A	26	14	27	M10	26~28				
BE28A	28	14	27	M10	28~30				
BE30A	30	14	27	M10	30~32				
BE32A	32	14	27	M10	32~34				
BE34A	34	14	27	M10	34~36				
BE36A	36	14	27	M10	36~38				
BE38A	38	14	27	M10	38~40				
BE40A	40	14	27	M10	40~42				
BE42A	42	14	27	M10	42~44				
BE44A	44	14	27	M10	44~46				
BE46A	46	14	27	M10	46~48				
BE48A	48	14	27	M10	48~50				
BE50A	50	14	27	M10	50~52				

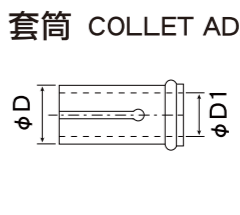
產品編號 Model No.	Dimensions.mm		Shape	適用鎢鋼柄 Suitable Adapters
	D	D1		
EC1605	16	5	套筒 COLLET ADAPTERS 	SC05H-SWUBR-06
EC1606	16	6		SC06J-SWUBR-06
EC1608	16	8		SC08-M5-..
EC1610	16	10		SC10-M6-..
EC1612	16	12		SC12-M6-..
EC1614	16	14		SC14-M6-..

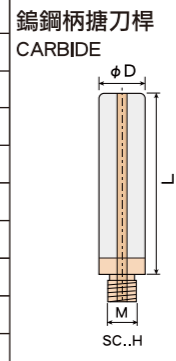
產品編號 Model No.	Dimensions.mm			Shape	適用搪刀頭 Suitable Boring Cutter Head	適用套筒 Suitable Collet		
	D	M	L					
SC08H-M5-115	8	M5	115	鎢鋼柄搪刀桿 CARBIDE 	BE09A、BE10.5A	EC1608		
SC10H-M6-115	10	M6	115		BE12A、BE14A BE16A	EC1610		
SC10H-M6-135	10	M6	135			EC1610		
SC10H-M6-160	10	M6	160			EC1612		
SC12H-M6-135	12	M6	135			EC1612		
SC12H-M6-165	12	M6	165		BE14A、BE16A	EC1614		
SC14H-M6-160	14	M6	160			BE18A~BE50A	—	
SC16H-M10-105	16	M10	105		BE18A~BE50A		—	
SC16H-M10-140	16	M10	140				BE18A~BE50A	—
SC16H-M10-180	16	M10	180					BE18A~BE50A

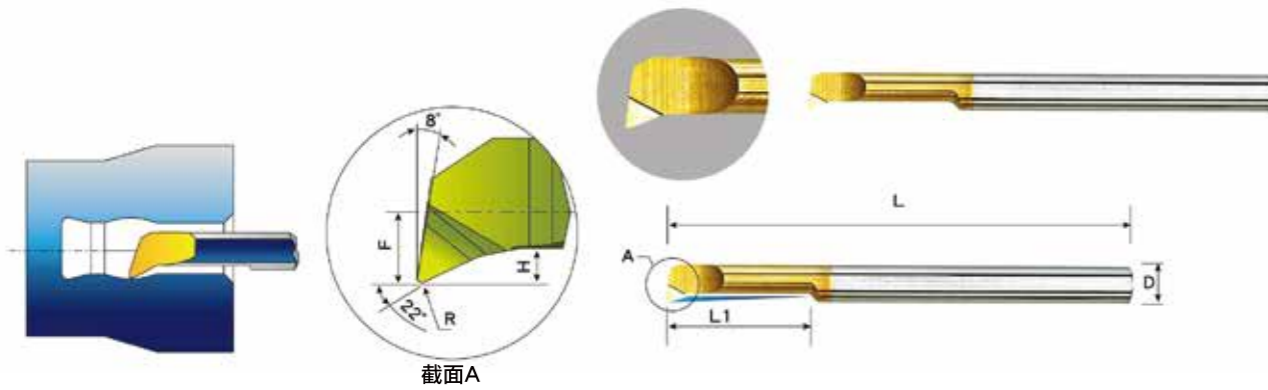

**MPR 微型車刀** Micro Turning Cutter

Model No.	D	L	L1	R	H	F	最小孔徑 Min Aperture	刀柄	價格	備註
MPR 1.5 R0.1 L6	3.0	50	6	0.10	0.3	0.7	1.5	SIM 0020 H3		
MPR 2 R0.1 L10	3.0	50	10	0.10	0.5	0.8	2.1	SIM 0020 H3		
MPR 3 R0.1 L15	3.0	50	15	0.10	0.7	1.3	3.1	SIM 0020 H3		
MPR 4 R0.1 L22	4.0	50	22	0.10	0.8	1.7	4.1	SIM 0020 H4		
MPR 6 R0.2 L22	6.0	50	22	0.20	1.4	2.8	6.1	SIM 0020 H6		
MPR 8 R0.2 L22	8.0	60	22	0.20	1.6	3.8	8.1	SIM 0020 H8		
MPR 10 R0.2 L35	10.0	75	35	0.20	2.0	4.8	10.1	SIM 0020 H10		

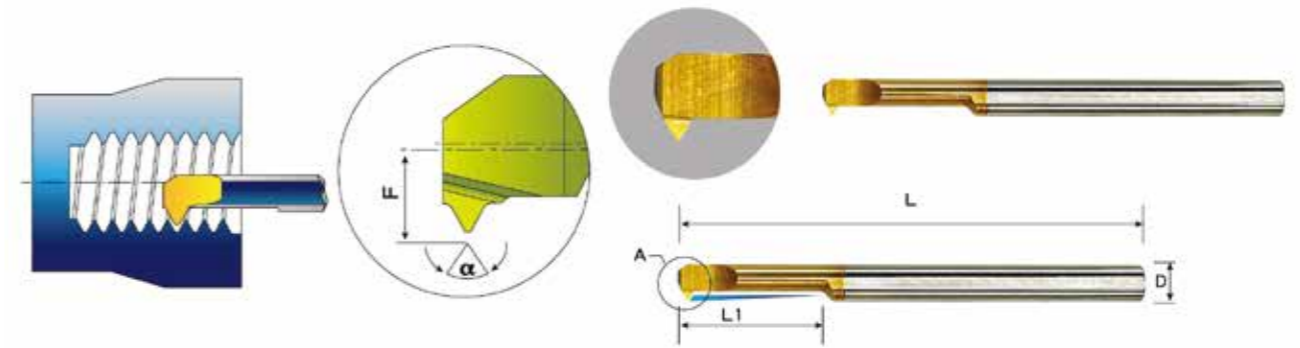

**MIR 微型車刀 (60° 螺紋加工)**

Micro Turning Cutter (60° Thread Processing)

Model No.	D	L	L1	α	螺距		F	最小孔徑 Min Aperture	刀柄	價格	備註
					mm	牙數/英寸 Teeth / inch					
MIR 3 L15 A60	3.0	39	15	60	0.8-1.0	32-24	1.4	3.2	SIM 0020 H3		
MIR 4 L15 A60	4.0	50	15	60	0.8-1.0	32-24	1.8	4.1	SIM 0020 H4		
MIR 6 L15 A60	6.0	50	15	60	1.0-1.5	24-16	2.6	6.0	SIM 0020 H6		
MIR 8 L22 A60	8.0	65	22	60	1.0-2.0	24-13	3.6	8.0	SIM 0020 H8		

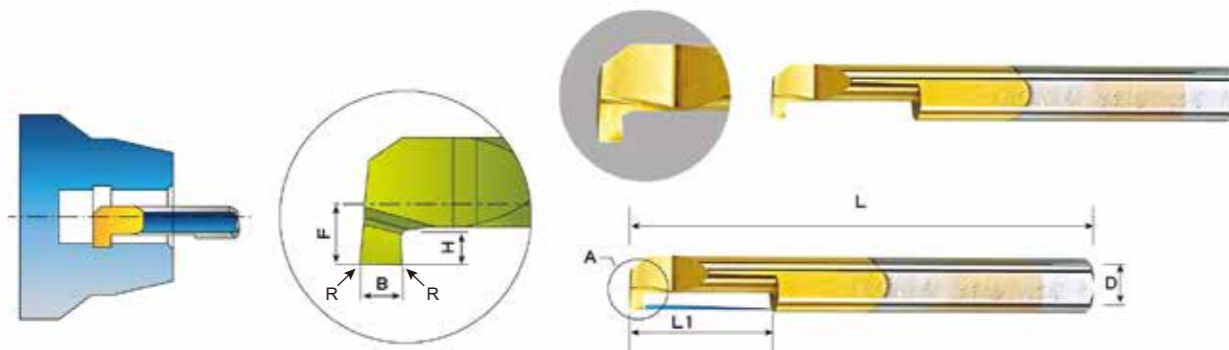

**MGR 微型車刀 (切槽)** Micro Turning Cutter (Recessed)

Model No.	D	L	L1	R	B	H	F	最小孔徑	刀柄	價格	備註
MGR 4 B1.0 L10	4.0	50	10	0.1	1.0	1.0	1.7	4.1	SIM 0020 H4		
MGR 4 B1.5 L10	4.0	50	10	0.1	1.5	1.0	1.7	4.1	SIM 0020 H4		
MGR 6 B1.0 L15	6.0	50	15	0.1	1.0	1.4	2.8	6.1	SIM 0020 H6		
MGR 6 B1.5 L15	6.0	50	15	0.1	1.5	1.4	2.8	6.1	SIM 0020 H6		
MGR 6 B2.0 L15	6.0	50	15	0.1	2.0	1.4	2.8	6.1	SIM 0020 H6		

庫存齊全、其他規格請另洽詢

**模具三寶**

THREE TREASURES FOR MOLD





### 錫鋼直柄長刃鑽頭

Solid Carbide Long Flute Straight Shank Drills

頂角：φ1~φ6=120°  
Top Angle φ6.1~φ13=140°



單位：mm (Unit : mm)

刃徑 D Diameter	溝長 Le Ditch Length	全長 L Overall Length	價格 Price	刃徑 D Diameter	溝長 Le Ditch Length	全長 L Overall Length	價格 Price	刃徑 D Diameter	溝長 Le Ditch Length	全長 L Overall Length	價格 Price
1.0	12	34		5.1	52	86		9.1	75	125	
1.1	12	36		5.2	52	86		9.2	75	125	
1.2	16	38		5.3	52	86		9.3	75	125	
1.3	16	38		5.4	57	93		9.4	75	125	
1.4	18	40		5.5	57	93		9.5	75	125	
1.5	18	40		5.6	57	93		9.6	80	133	
1.6	20	43		5.7	57	93		9.7	80	133	
1.7	20	43		5.8	57	93		9.8	80	133	
1.8	22	46		5.9	57	93		9.9	80	133	
1.9	22	46		6.0	57	93		10.0	80	133	
2.0	24	49		6.1	63	101		10.1	80	133	
2.1	24	49		6.2	63	101		10.2	80	133	
2.2	27	53		6.3	63	101		10.3	80	133	
2.3	27	53		6.4	63	101		10.4	80	133	
2.4	30	57		6.5	63	101		10.5	80	133	
2.5	30	57		6.6	63	101		10.6	80	133	
2.6	30	57		6.7	63	101		10.7	80	142	
2.7	33	61		6.8	69	109		10.8	80	142	
2.8	33	61		6.9	69	109		10.9	80	142	
2.9	33	61		7.0	69	109		11.0	80	142	
3.0	33	61		7.1	69	109		11.1	80	142	
3.1	36	65		7.2	69	109		11.2	80	142	
3.2	36	65		7.3	69	109		11.3	80	142	
3.3	36	65		7.4	69	109		11.4	80	142	
3.4	39	70		7.5	69	109		11.5	80	142	
3.5	39	70		7.6	75	117		11.6	80	142	
3.6	39	70		7.7	75	117		11.7	80	142	
3.7	39	70		7.8	75	117		11.8	80	142	
3.8	43	75		7.9	75	117		11.9	80	151	
3.9	43	75		8.0	75	117		12.0	80	151	
4.0	43	75		8.1	75	117		12.1	80	151	
4.1	43	75		8.2	75	117		12.2	80	151	
4.2	43	75		8.3	75	117		12.3	80	151	
4.3	47	80		8.4	75	117		12.4	80	151	
4.4	47	80		8.5	75	117		12.5	80	151	
4.5	47	80		8.6	75	125		12.6	80	151	
4.6	47	80		8.7	75	125		12.7	80	151	
4.7	47	80		8.8	75	125		12.8	80	151	
4.8	52	86		8.9	75	125		12.9	80	151	
4.9	52	86		9.0	75	125		13.0	80	151	
5.0	52	86									

### 錫鋼銑刀柄機械鉸刀

Solid Carbide Machine Reamers

左旋右刃：7°  
刃徑公差：+0.003~+0.005  
※刃徑以0.01為最小單位

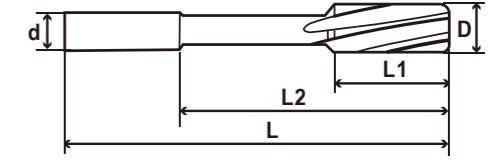

單位：mm (Unit : mm)

刃徑 D Diameter	刃長 L1 Flute Length	有效長 L2 Effective Length	柄徑 d Shank Diameter	刃數 T Teeth	全長 L Overall Length	價格 Price	備註
1.5	8	18	3	4	50		
1.6	9	20	3	4	50		
1.7	9	20	3	4	50		
1.8	10	22	3	4	50		
1.9	10	22	3	4	50		



**鎢鋼直柄機械鉸刀**

Solid Carbide Straight Shank Machine Reamers

左旋右刃：7°  
刃徑公差：+0.002~+0.008

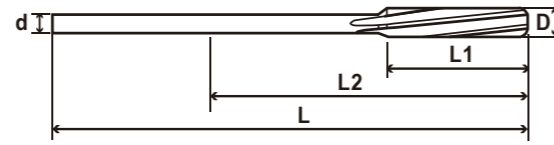

單位：mm (Unit : mm)

刃徑 D Diameter	刃長 L1 Flute Length	有效長 L2 Effective Length	刃數 T Teeth	全長 L Overall Length	價格 Price
2	11	24	4	49	
2.1	11	24	4	49	
2.2	12	26	4	53	
2.3	12	26	4	53	
2.4	14	28	4	57	
2.5	14	28	4	57	
2.6	14	28	4	57	
2.7	15	32	4	61	
2.8	15	32	4	61	
2.9	15	32	4	61	
3	15	32	4	61	
3.1	16	35	4	65	
3.2	16	35	4	65	
3.3	16	35	4	65	
3.4	18	40	4	70	
3.5	18	40	4	70	
3.6	18	40	4	70	
3.7	18	40	4	70	
3.8	19	43	4	75	
3.9	19	43	4	75	
4	19	43	4	75	
4.1	19	43	4	75	
4.2	19	43	4	75	
4.3	21	47	4	80	
4.4	21	47	4	80	
4.5	21	47	4	80	
4.6	21	47	4	80	
4.7	21	47	4	80	
4.8	23	52	4	86	
4.9	23	52	4	86	

刃徑 D Diameter	刃長 L1 Flute Length	有效長 L2 Effective Length	刃數 T Teeth	全長 L Overall Length	價格 Price
5	23	52	4	86	
5.1	23	52	4	86	
5.2	23	52	4	86	
5.3	23	52	4	86	
5.4	26	57	4	93	
5.5	26	57	4	93	
5.6	26	57	4	93	
5.7	26	57	4	93	
5.8	26	57	4	93	
5.9	26	57	4	93	
6	26	57	6	93	
6.1	28	63	6	101	
6.2	28	63	6	101	
6.3	28	63	6	101	
6.4	28	63	6	101	
6.5	28	63	6	101	
6.6	28	63	6	101	
6.7	28	63	6	101	
6.8	31	69	6	109	
6.9	31	69	6	109	
7	31	69	6	109	
7.1	31	69	6	109	
7.2	31	69	6	109	
7.3	31	69	6	109	
7.4	31	69	6	109	
7.5	31	69	6	109	
7.6	33	75	6	117	
7.7	33	75	6	117	
7.8	33	75	6	117	
7.9	33	75	6	117	

**鎢鋼直柄機械鉸刀**

Solid Carbide Straight Shank Machine Reamers

左旋右刃：7°  
刃徑公差：+0.002~+0.008

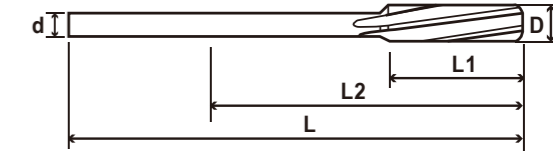

單位：mm (Unit : mm)

刃徑 D Diameter	刃長 L1 Flute Length	有效長 L2 Effective Length	刃數 T Teeth	全長 L Overall Length	價格 Price
8	33	75	6	117	
8.1	33	75	6	117	
8.2	33	75	6	117	
8.3	33	75	6	117	
8.4	33	75	6	117	
8.5	33	75	6	117	
8.6	36	81	6	125	
8.7	36	81	6	125	
8.8	36	81	6	125	
8.9	36	81	6	125	
9	36	81	6	125	
9.1	36	81	6	125	
9.2	36	81	6	125	
9.3	36	81	6	125	
9.4	36	81	6	125	
9.5	36	81	6	125	
9.6	38	87	6	133	
9.7	38	87	6	133	
9.8	38	87	6	133	
9.9	38	87	6	133	
10	38	87	6	133	
10.1	38	87	6	133	
10.2	38	87	6	133	
10.3	38	87	6	133	
10.4	38	87	6	133	
10.5	38	87	6	133	
10.6	38	87	6	133	
10.7	41	96	6	142	
10.8	41	96	6	142	
10.9	41	96	6	142	

刃徑 D Diameter	刃長 L1 Flute Length	有效長 L2 Effective Length	刃數 T Teeth	全長 L Overall Length	價格 Price
11	41	96	6	142	
11.1	41	96	6	142	
11.2	41	96	6	142	
11.3	41	96	6	142	
11.4	41	96	6	142	
11.5	41	96	6	142	
11.6	41	96	6	142	
11.7	41	96	6	142	
11.8	41	96	6	142	
11.9	44	105	6	151	
12	44	105	6	151	
12.1	44	105	6	151	
12.2	44	105	6	151	
12.3	44	105	6	151	
12.4	44	105	6	151	
12.5	44	105	6	151	
12.6	44	105	6	151	
12.7	44	105	6	151	
12.8	44	105	6	151	
12.9	44	105	6	151	
13	44	105	6	151	
14	44	105	6	151	
15	44	105	6	151	
16	44	105	6	151	

**鎢鋼直柄機械鉸刀(精密型)**

Tungsten Carbide Machine Reamer(Micro Decimal Diameter)

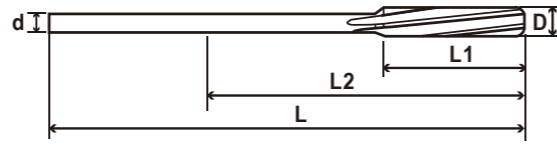

左旋右刃：7° 刃徑公差：+0.003~+0.005

★刃徑以0.01為單位

單位：mm (Unit : mm)

刃徑 D Diameter	刃長 L1 Flute Length	有效長 L2 Effective Length	刃數 T Teeth	全長 L Overall Length	價格 Price	備註
1.95 ~ 1.99	11	24	4	49		
2.95 ~ 2.99	15	32	4	61		
3.95 ~ 3.99	19	43	4	75		
4.95 ~ 4.99	23	52	4	86		
5.95 ~ 5.99	26	57	6	93		
6.95 ~ 6.99	31	69	6	109		
7.95 ~ 7.99	33	75	6	117		
8.95 ~ 8.99	36	81	6	125		
9.95 ~ 9.99	38	87	6	133		
10.95 ~ 10.99	41	96	6	142		
11.95 ~ 11.99	44	105	6	151		
12.95 ~ 12.99	44	105	6	151		

**鎢鋼直柄機械鉸刀(加長型)**

Tungsten Carbide Machine Reamer(Long Shank)

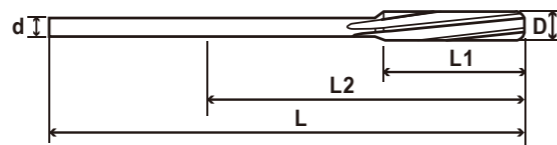

左旋右刃：7° 刃徑公差：+0.002~+0.008

★刃徑以0.01為單位

單位：mm (Unit : mm)

刃徑 D Diameter	刃長 L1 Flute Length	有效長 L2 Effective Length	刃數 T Teeth	全長 L Overall Length	價格 Price	備註
3	15	32	4	100		
4	19	43	4	120		
5	23	52	4	132		
6	26	57	6	150		
7	31	69	6	150		
8	33	75	6	150		
9	36	81	6	180		
10	38	87	6	180		

**HSS  
高速鋼**

**星型六角起子頭**  
HSS High Speed Steel Torx Screwdriver Bits

星型形狀保持度佳、高硬度、耐磨耗、不易滑牙

單位：mm



規格	柄徑	全長
T-6	6.35	54
T-7	6.35	54
T-8	6.35	54
T-9	6.35	54
T-10	6.35	54
T-15	6.35	54
T-20	6.35	54

可快速互換



**捨棄式刀具專用星型起子**

HSS Torx Screwdriver for Indexable Insert Cutting Tools

易握手把、省力防滑 其他款式需求，歡迎與我們詢問



T-6 T-7 T-8 T-9 T-10 T-15 T-20



## HSS 高速鋼星型六角起子頭

HSS High Speed Steel TORX Professional Bit

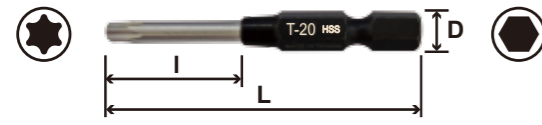

單位：mm (Unit : mm)

產品編號 Model No.		長度 l Length	柄徑 D Handle Diameter	全長 L Overall Length	備註 Note
FYW02T06BIT	T06	22.5	6.35 (1/4")	55	
FYW02T07BIT	T07	22.5	6.35 (1/4")	55	
FYW02T08BIT	T08	22.5	6.35 (1/4")	55	
FYW02T09BIT	T09	22.5	6.35 (1/4")	55	
FYW02T10BIT	T10	22.5	6.35 (1/4")	55	
FYW02T15BIT	T15	22.5	6.35 (1/4")	55	
FYW02T20BIT	T20	22.5	6.35 (1/4")	55	
FY520 Handle	—	—	—	—	

## HSS 高速鋼六角起子頭

HSS High Speed Steel HEX Professional Bit



單位：mm (Unit : mm)

產品編號 Model No.		長度 l Length	柄徑 D Handle Diameter	全長 L Overall Length	備註 Note
FYW02H015BIT	H1.5	44.0	6.35 (1/4")	75	
FYW02H020BIT	H2.0	50.0	6.35 (1/4")	80	
FYW02H025BIT	H2.5	59.5	6.35 (1/4")	90	
FYW02H030BIT	H3.0	61.0	6.35 (1/4")	92	
FY520 Handle	—	—	—	—	

## HSS 高速鋼十字起子頭

HSS High Speed Steel Phillips Professional Bit

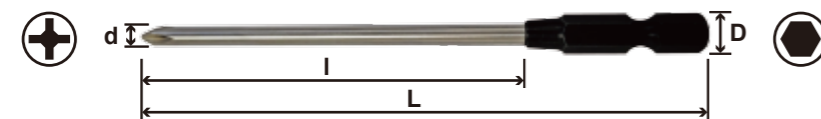

單位：mm (Unit : mm)

產品編號 Model No.		l x d	柄徑 D Handle Diameter	全長 L Overall Length	備註 Note
FYW02PH00BIT	PH00	45 x 2.0	6.35 (1/4")	78	
FYW02PH0BIT	PH0	62 x 3.0	6.35 (1/4")	92	
FYW02PH1BIT	PH1	73 x 4.0	6.35 (1/4")	104	
FYW02PH2BIT	PH2	73 x 4.0	6.35 (1/4")	104	
FY520 Handle	—	—	—	—	

### HSS 高速鋼捨棄式刀具專用星型起子

HSS High Speed Steel TORX Screwdriver

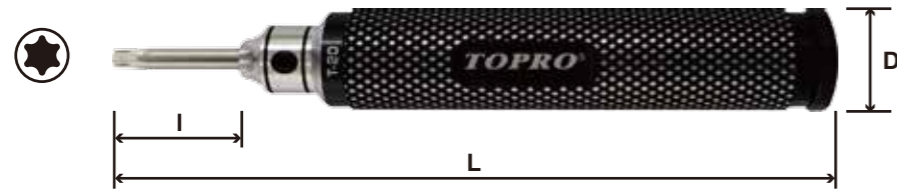

單位：mm (Unit : mm)

產品編號 Model No.		長度   Length	柄徑 D Handle Diameter	全長 L Overall Length	備註 Note
VV1GT06HSS488	T06	23	18	130	
VV1GT07HSS488	T07	23	18	130	
VV1GT08HSS488	T08	23	18	130	
VV1GT09HSS488	T09	23	18	130	
VV1GT10HSS488	T10	23	18	130	
VV1GT15HSS488	T15	23	18	130	
VV1GT20HSS488	T20	23	18	130	

### HSS 高速鋼捨棄式刀具專用星型起子芯

HSS High Speed Steel TORX Screwdriver Interchangeable Bit



單位：mm (Unit : mm)

產品編號 Model No.		長度   Bit Length	備註 Note
FYW5VT06HSS36	T06	36	
FYW5VT07HSS36	T07	36	
FYW5VT08HSS36	T08	36	
FYW5VT09HSS36	T09	36	
FYW5VT10HSS36	T10	36	
FYW5VT15HSS36	T15	36	
FYW5VT20HSS36	T20	36	

### 專利走心式車床專用螺帽棘輪扳手

Ratchet Wrench for Swiss Type CNC Lathe



單位：mm (Unit : mm)

產品編號 Model No.		總長度 L Overall Length	備註 Note
RX1GER11M	ER11M	110	
RX1GER16M	ER16M	130	
RX1GER20M	ER20M	160	

### 專利走心式車床專用星型棘輪扳手

HSS TROX Bit of Ratchet Wrench for Swiss Type CNC Lathe



單位：mm (Unit : mm)

產品編號 Model No.		總長度 L Overall Length	備註 Note
RX1G02510	T6~T15	140	

### 鎢鋼倒角起子頭

Made in Taiwan Tungsten Carbide Steel Chamfering / Deburring Tool



單位 : mm (Unit : mm)

產品編號 Model No.	刃徑 D Diameter	角度 Top Angle	刃數 T Number of Flute	柄徑 D Handle Diameter	備註 Note
2R2FYW 0803	8	90°	3	6.35 (1/4")	
2R2FYW 1103	11	90°	3	6.35 (1/4")	
2R2FYW 1303	13	90°	3	6.35 (1/4")	
2R2FYW 1703	17	90°	3	6.35 (1/4")	
2R2FYW 2103	21	90°	3	6.35 (1/4")	
FY520 Handle	—	—	—	—	

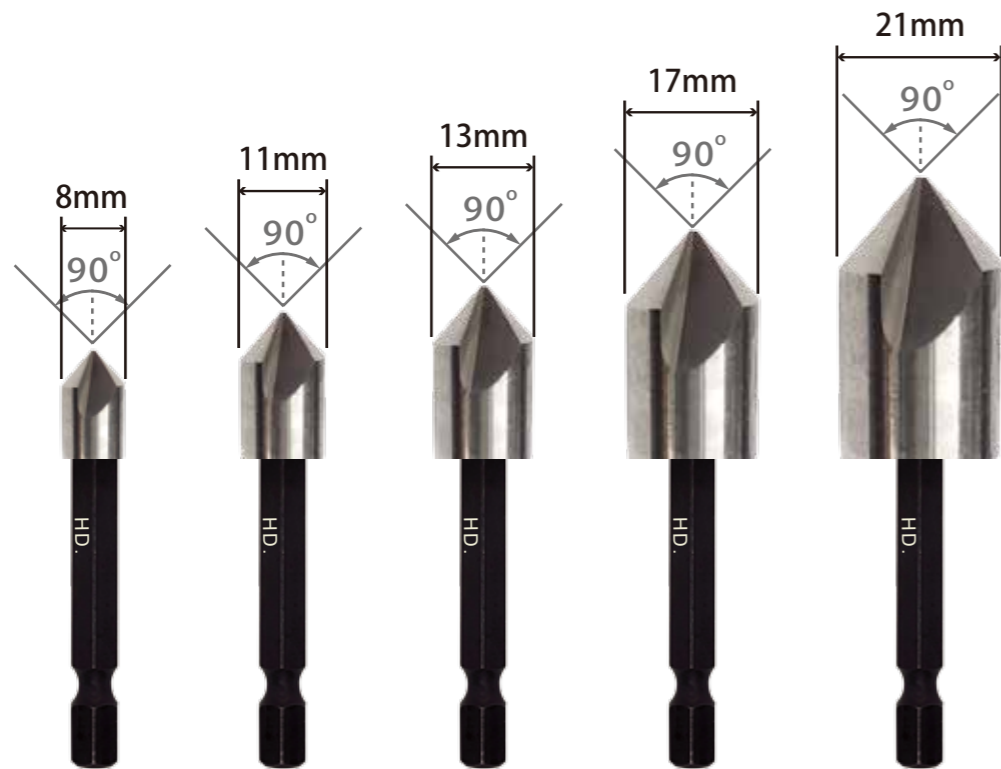

# 鎢鋼倒角刀起子頭

Tungsten Carbide Chamfering cutter

手持式去毛刺工具

Material are all tungsten Carbide

全鎢鋼  
材質



鎢鋼倒角刀起子頭

可快速互換  
Easy to quick interchangeable

充電式手持倒角刀



耐磨耗 / 快速便利 / 可裝於起子柄  
也可用於電鑽上使用  
電動手持倒角刀  
多種長度變化可供選擇  
使用不受場地限制  
狹小處亦可操作

**HD.MIT**



■ 側面切削 Side Milling

ERVD

工件材料 Work Material	一般構造用鋼，碳素鋼，鑄鐵 Mild steels, Carbon Steel, Cast Iron SS400, S55c, FC250 (~750N/mm)		調質鋼，不鏽鋼 (38~45HRC) Hardened Steel Stainless Steel SUS304, NAK, SKD		耐熱合金，鈦合金 Ti-6Al-4V Nickel Alloy Titanium Alloy		超耐熱合金，鎳鎳鐵合金718 Super-heat resistant Alloy inconel718	
	直徑 (mm) Diameter	回轉數 (rpm) Speed	進給速度 mm/min Feed Rate	回轉數 (rpm) Speed	進給速度 mm/min Feed Rate	回轉數 (rpm) Speed	進給速度 mm/min Feed Rate	回轉數 (rpm) Speed
切削速度 (Vc) Cutting Speed	75-160 m/min		120 m/min		85 m/min		35 m/min	
3	9,550	1,530	9,550	760	6,685	532	9,375	220
4	7,960	2,550	7,960	950	5,572	665	2,800	230
5	7,640	2,630	7,320	1,200	5,124	840	2,240	260
6	6,900	3,000	6,900	1,650	4,830	1,155	1,865	260
8	5,570	3,340	5,570	1,560	3,899	1,092	1,400	260
10	5,000	3,600	4,770	1,630	3,339	1,141	1,120	210
12	3,980	3,180	3,980	1,430	2,786	1,001	935	190
16	2,980	2,380	2,380	950	1,666	665	700	140
切削量基準 Depth of cut (D:直徑Dia.)	<p><math>A_p \leq 2.0D</math> <math>A_e \leq 0.1D</math></p>		<p><math>A_p \leq 1.0D</math> <math>A_e \leq 0.1D</math></p>		<p><math>A_p \leq 1.0D</math> <math>A_e \leq 0.05D</math></p>			

■ 側面切削 Side Milling

CED

工件材料 Work Material	一般構造用鋼，碳素鋼，鑄鐵 Mild steels, Carbon Steel, Cast Iron SS400, S55c, FC250 (~750N/mm)		調質鋼，不鏽鋼 (38~45HRC) Hardened Steel Stainless Steel SUS304, NAK, SKD		耐熱合金，鈦合金 Ti-6Al-4V Nickel Alloy Titanium Alloy	
	直徑 (mm) Diameter	回轉數 (rpm) Speed	進給速度 mm/min Feed Rate	回轉數 (rpm) Speed	進給速度 mm/min Feed Rate	回轉數 (rpm) Speed
切削速度 (Vc) Cutting Speed	130 m/min		120 m/min		85 m/min	
3	9,550	1,140	9,550	600	6,685	420
4	7,960	1,575	7,960	800	5,572	560
5	7,100	1,430	6,680	860	4,676	602
6	6,890	1,650	5,840	930	4,088	651
8	5,570	2,230	4,775	1,150	3,343	805
10	4,500	2,800	4,140	1,160	2,898	812
12	3,710	2,370	3,710	1,190	2,597	833
16	2,590	1,650	2,590	1,860	1,813	1,302
切削量基準 Depth of cut (D:直徑Dia.)	<p><math>A_p \leq 2.0D</math> <math>A_e \leq 0.1D</math></p>				<p><math>A_p \leq 1.0D</math> <math>A_e \leq 0.1D</math></p>	

■ 溝切削 Slotting

ERVD

工件材料 Work Material	一般構造用鋼，碳素鋼，鑄鐵 Mild steels, Carbon Steel, Cast Iron SS400, S55c, FC250 (~750N/mm)		調質鋼，不鏽鋼 (38~45HRC) Hardened Steel Stainless Steel SUS304, NAK, SKD		耐熱合金，鈦合金 Ti-6Al-4V Nickel Alloy Titanium Alloy		超耐熱合金，鎳鎳鐵合金718 Super-heat resistant Alloy inconel718	
	直徑 (mm) Diameter	回轉數 (rpm) Speed	進給速度 mm/min Feed Rate	回轉數 (rpm) Speed	進給速度 mm/min Feed Rate	回轉數 (rpm) Speed	進給速度 mm/min Feed Rate	回轉數 (rpm) Speed
切削速度 (Vc) Cutting Speed	75-160 m/min		120 m/min		75 m/min		30 m/min	
3	9,550	700	9,550	300	6,685	210	3,200	130
4	8,000	800	7,960	450	5,572	315	2,900	130
5	7,320	1,170	7,320	530	5,124	371	1,920	130
6	6,900	1,380	6,366	630	4,456	441	1,600	150
8	5,570	1,560	4,775	760	3,343	532	1,200	150
10	4,500	1,650	4,138	660	2,897	462	960	130
12	3,450	1,100	3,180	500	2,226	350	800	120
16	2,380	760	2,380	380	1,666	266	600	90
切削量基準 Depth of cut (D:直徑Dia.)	<p><math>A_p \leq 1.0D</math> <math>A_e \leq 1.0D</math></p>		<p><math>A_p \leq 0.5D</math> <math>A_e \leq 1.0D</math></p>		<p><math>A_p \leq 0.15D</math> <math>A_e \leq 1.0D</math></p>			

【注意】

- 1) 請使用剛性及精準度較佳之機械與夾頭。
- 2) 當切削量過大或機械剛性不足時，請降低回轉數及進給速度。
- 3) 請使用不易產生煙霧之切削液。
- 4) 在乾式切削時，請用空氣將切屑吹離加工範圍。

【NOTE】

- 1) Use a rigid and precise machine and holder.
- 2) Please adjust the speed and feed when the cutting depth is large or when machines with low rigidity are used.
- 3) Please use a suitable fluid with high smoke rstandant properties.
- 4) During DRY (no fluid) milling, please use air blow to remove disposable chips from the moilling area and to eliminate chip packing.

■ 溝切削 Slotting

CED

工件材料 Work Material	一般構造用鋼，碳素鋼，鑄鐵 Mild steels, Carbon Steel, Cast Iron SS400, S55c, FC250 (~750N/mm)		調質鋼，不鏽鋼 (38~45HRC) Hardened Steel Stainless Steel SUS304, NAK, SKD		耐熱合金，鈦合金 Ti-6Al-4V Nickel Alloy Titanium Alloy	
	直徑 (mm) Diameter	回轉數 (rpm) Speed	進給速度 mm/min Feed Rate	回轉數 (rpm) Speed	進給速度 mm/min Feed Rate	回轉數 (rpm) Speed
切削速度 (Vc) Cutting Speed	130 m/min		120 m/min		75 m/min	
3	9,550	500	9,550	300	6,685	210
4	7,960	570	7,960	450	5,572	315
5	7,100	600	7,320	530	5,124	371
6	6,750	700	6,366	630	4,456	441
8	4,770	1,140	4,775	760	3,343	532
10	3,800	1,070	4,138	660	2,897	462
12	2,920	700	3,180	500	2,226	350
16	2,190	530	2,380	380	1,666	266
切削量基準 Depth of cut (D:直徑Dia.)	<p><math>A_p \leq 1.0D</math> <math>A_e \leq 1.0D</math></p>				<p><math>A_p \leq 0.5D</math> <math>A_e \leq 1.0D</math></p>	

【注意】

- 1) 請使用剛性及精準度較佳之機械與夾頭。
- 2) 當切削量過大或機械剛性不足時，請降低回轉數及進給速度。
- 3) 請使用不易產生煙霧之切削液。
- 4) 在乾式切削時，請用空氣將切屑吹離加工範圍。

【NOTE】

- 1) Use a rigid and precise machine and holder.
- 2) Please adjust the speed and feed when the cutting depth is large or when machines with low rigidity are used.
- 3) Please use a suitable fluid with high smoke rstandant properties.
- 4) During DRY (no fluid) milling, please use air blow to remove disposable chips from the moilling area and to eliminate chip packing.



切削條件表 Standard Cutting Conditions

SE.MHD.RTA

被削材 Work Material	炭素鋼,合金鋼(~30HRC) Carbon Steel, Alloy Steel S50C, SCM, 鑄鐵FC250等 AISI 1049, Cast iron			合金鋼, 工具鋼(30~45HRC) Alloy steel, Tool steel 預硬鋼, SKD61, NAK等 Pre-hardened steel, AISI H13			沃斯田鐵系不銹鋼 Austenitic stainless steel SUS304, SUS316等 AISI 304, AISI 316			熱處理鋼(45~55HRC) Hardened steel SKD61, SKD11, NAK, STAVAX等AISI H13			熱處理鋼(55~60HRC) Hardened steel SKD11等AISI D2		
削材速度 Cutting Speed	50~100m/min			50~70m/min			30~60m/min			30~50m/min			15~30m/min		
直徑 (mm) Diameter	回轉數 (min <sup>-1</sup> ) Speed	進給速度 mm/min Feed Rate		回轉數 (min <sup>-1</sup> ) Speed	進給速度 mm/min Feed Rate		回轉數 (min <sup>-1</sup> ) Speed	進給速度 mm/min Feed Rate		回轉數 (min <sup>-1</sup> ) Speed	進給速度 mm/min Feed Rate		回轉數 (min <sup>-1</sup> ) Speed	進給速度 mm/min Feed Rate	
		側面 Side Milling	溝 Slotting		側面 Side Milling	溝 Slotting		側面 Side Milling	溝 Slotting		側面 Side Milling	溝 Slotting		側面 Side Milling	溝 Slotting
1	30,000	900	720	20,000	600	480	12,600	450	270	15,000	180	140	4,800	30	24
1.5	20,000	900	720	14,000	600	480	8,400	450	270	10,000	180	140	3,200	35	28
2	15,000	900	720	10,000	600	480	6,300	450	270	8,000	180	140	2,400	40	32
2.5	12,000	900	720	8,200	600	480	5,100	450	270	6,100	180	140	2,100	45	36
3	10,000	900	720	7,000	600	480	4,200	450	270	5,000	180	140	1,800	55	44
4	7,500	900	720	5,200	600	480	3,100	450	270	4,000	180	140	1,400	75	60
5	6,000	900	720	4,200	600	480	2,500	450	270	3,200	180	140	1,200	75	60
6	5,000	900	430	3,500	600	480	2,100	450	270	2,700	180	140	1,000	75	60
8	4,000	780	620	2,800	520	410	1,600	390	230	2,000	160	125	800	70	56
10	3,200	680	540	2,200	450	360	1,300	340	200	1,600	140	110	650	65	52
12	2,700	620	490	1,900	410	320	1,100	310	180	1,300	120	95	530	55	44

【注意】【NOTE】

- 1) 切削60 HRC的材料時，請使用MS6P銑刀。  
Please Use MS6P for work materials of 60 HRC or above.
- 2) 切削沃斯田鐵系不銹鋼系列及耐熱合金時，請使用非水溶性切削油效果較好。  
In Cutting Austenitic stainless steels, the use of non-water-soluble cutting fluid is especially effective.
- 3) 機械設備或工件的夾持剛性不足、出現震動時，請以相同比例按上表降低回轉數及進給速度。  
If the rigidity of the machine or the work material installation is very low, or chattering is generated, please reduce the revolution and the feed rate proportionately.
- 4) 縱向進給時，進給速度請設定為上表之1/3以下。  
When drilling, please set feed rate at 1/3 or below of the above value.

高速切削條件表 High-Speed Milling Conditions

被削材 Work Material	炭素鋼,合金鋼(~30HRC) Carbon Steel, Alloy Steel S50C, SCM, 鑄鐵FC250等 AISI 1049, Cast iron		合金鋼, 工具鋼(30~45HRC) Alloy steel, Tool steel 預硬鋼, SKD61, NAK等 Pre-hardened steel, AISI H13		熱處理鋼(45~55HRC) Hardened steel SKD61, SKD11, NAK, STAVAX等AISI H13		熱處理鋼(55~60HRC) Hardened steel SKD11等AISI D2	
削材速度 Cutting Speed	300m/min		200m/min		150m/min		50m/min	
直徑 (mm) Diameter	回轉數 (min <sup>-1</sup> ) Speed	進給速度 mm/min Feed Rate	回轉數 (min <sup>-1</sup> ) Speed	進給速度 mm/min Feed Rate	回轉數 (min <sup>-1</sup> ) Speed	進給速度 mm/min Feed Rate	回轉數 (min <sup>-1</sup> ) Speed	進給速度 mm/min Feed Rate
2	40,000	2,400	30,000	1,800	23,800	530	7,900	130
3	30,000	2,700	21,200	1,800	15,900	530	5,300	160
4	23,800	2,850	15,900	1,800	11,900	530	4,000	210
5	19,000	2,850	12,700	1,800	9,500	530	3,200	200
6	15,900	2,850	10,600	1,800	7,900	530	2,650	200
8	11,900	2,325	7,900	1,485	5,900	470	2,000	175
10	9,500	2,000	6,300	1,290	4,700	410	1,600	160
12	7,900	1,800	5,300	1,125	3,900	360	1,300	135



切削條件表 Standard Cutting Conditions

SB

被削材 Work Material	炭素鋼 Carbon steels S50C		合金鋼, 調質鋼 Alloy steels Pre-hardened steels, SCM, SKD, SUS, HPM, NAK		熱處理鋼 Hardened steels SKD61(~55HRC)		鋁 Aluminum		銅 Copper	
削材速度 Cutting Speed	150m/min		120~150m/min		80~100m/min		150~m/min		100~150~m/min	
R	回轉數 (min <sup>-1</sup> ) Speed	進給速度 mm/min Feed Rate	回轉數 (min <sup>-1</sup> ) Speed	進給速度 mm/min Feed Rate	回轉數 (min <sup>-1</sup> ) Speed	進給速度 mm/min Feed Rate	回轉數 (min <sup>-1</sup> ) Speed	進給速度 mm/min Feed Rate	回轉數 (min <sup>-1</sup> ) Speed	進給速度 mm/min Feed Rate
0.2	40,000	500	40,000	480	40,000	500	40,000	480	40,000	480
0.25	40,000	620	40,000	610	40,000	620	40,000	540	40,000	540
0.3	40,000	750	40,000	1,000	40,000	750	40,000	600	40,000	600
0.4	40,000	960	40,000	1,200	36,000	900	40,000	800	40,000	800
0.5	40,000	1,200	38,000	1,100	29,000	900	40,000	1,000	40,000	830
0.75	30,000	1,270	25,500	800	19,000	700	40,000	1,360	30,000	1,160
1	24,000	1,160	19,000	670	14,000	600	40,000	2,000	24,000	1,200
1.25	19,000	1,000	15,300	600	11,500	510	38,000	2,400	19,000	1,200
1.5	16,000	930	13,000	580	9,600	460	32,000	2,400	16,000	1,200
1.75	13,700	930	11,400	570	8,200	450	27,300	2,400	13,000	1,200
2	12,000	930	10,000	560	7,200	450	24,000	2,400	12,000	1,200
2.5	9,600	930	8,000	540	5,700	450	19,000	2,400	9,600	1,200
3	8,000	930	6,400	540	4,800	450	16,000	2,400	8,000	1,200
4	6,000	900	4,800	540	3,600	450	12,000	2,400	6,000	1,200
5	4,800	900	3,800	540	2,900	450	9,600	2,300	4,800	1,150
6	4,000	900	3,200	540	2,400	450	8,000	2,100	4,000	1,050



【注意】【NOTE】

- 1) 溝加工時之進給速度，請設定為上數值之60%。  
When slotting, reduce the feed by 60% from above values.
- 2) 刀具夾持突出量，以4D為基準，超出上述場合時；請將切削條件作適度之調整。  
Length of overhang is 4 times dia. as standard. When it is longer then 4 times dia., flow figures of above table.
- 3) 請使用油霧(Oil-mist)冷卻或吹氣方式(Air blow)進行切削。  
Use Oil-mist coolant or Air blow.
- 4) 主軸回轉數及床台進給速度，請以相同比例作適度調整。  
Adjust both spindle speed and feed according to milling conditions and machine rigidity.



高速切削條件表 High-Speed Milling Conditions

SB

被削材 Work Material	炭素鋼 Carbon steels S50C		合金鋼 Alloy steels SCM,SKD,SUS		調質鋼 Pre-hardened steels HPM,NAK		熱處理鋼 Hardened steels SKD61(~55HRC)	
	250 m/min		200 m/min		180 m/min		100 m/min	
削材速度 Cutting Speed	250 m/min		200 m/min		180 m/min		100 m/min	
R	回轉數 (min <sup>-1</sup> ) Speed	進給速度 mm/min Feed Rate	回轉數 (min <sup>-1</sup> ) Speed	進給速度 mm/min Feed Rate	回轉數 (min <sup>-1</sup> ) Speed	進給速度 mm/min Feed Rate	回轉數 (min <sup>-1</sup> ) Speed	進給速度 mm/min Feed Rate
0.15	~40,000	~1,200	~40,000	~960	~40,000	~800	~40,000	350
0.2	~40,000	~1,200	~40,000	~960	~40,000	~800	~40,000	480
0.25	~40,000	~1,200	~40,000	~960	~40,000	~800	~40,000	520
0.3	~40,000	~1,200	~40,000	~960	~40,000	~800	~40,000	560
0.4	~40,000	~2,400	~40,000	~2,000	~40,000	~1,760	40,000	1,000
0.5	~40,000	~2,400	~40,000	~2,000	~40,000	~1,760	32,000	1,500
0.75	~40,000	~3,700	~40,000	~3,000	38,000	2,700	21,300	1,500
1	40,000	5,000	32,000	3,200	29,000	2,900	16,000	1,500
1.25	32,000	5,000	25,000	3,200	23,000	2,900	12,800	1,500
1.5	27,000	5,000	21,000	3,200	19,000	2,900	10,600	1,500
1.75	23,000	5,000	18,000	3,200	16,400	2,900	9,100	1,500
2	20,000	4,000	16,000	3,200	14,000	2,900	8,000	1,500
2.5	16,000	3,500	12,800	2,500	11,500	2,300	6,400	1,300
3	13,500	3,000	10,600	2,000	9,500	1,800	5,300	1,200
4	10,000	3,000	8,000	2,000	7,200	1,800	4,000	1,200
5	8,000	3,000	6,400	2,000	5,700	1,800	3,200	1,200
6	6,700	2,500	5,300	1,800	4,800	1,800	2,700	1,200

  

切削量基準 Depth of cut (R:球頭半徑)		
-----------------------------------	--	--

■ 球型銑刀實際加工直徑速查表 Ball End Milling Actual Diameter

SB

R半徑 R	刃徑 D	加工深度 Depth of cut (mm)															
		0.01	0.02	0.03	0.04	0.05	0.08	0.1	0.15	0.2	0.3	0.5	0.8	1	2	3	
0.1	0.2	0.087	0.12	0.143	0.16	0.173	0.196	0.2									
0.2	0.4	0.125	0.174	0.211	0.24	0.265	0.32	0.35	0.39	0.4							
0.3	0.6	0.154	0.215	0.262	0.299	0.332	0.41	0.45	0.52	0.57	0.6						
0.4	0.8	0.178	0.25	0.304	0.349	0.387	0.48	0.53	0.62	0.69	0.77						
0.5	1	0.199	0.28	0.341	0.392	0.436	0.54	0.6	0.71	0.8	0.92	1					
1	2	0.282	0.398	0.486	0.56	0.624	0.78	0.87	1.05	1.2	1.43	1.73	1.96	2			
1.5	3	0.346	0.488	0.597	0.688	0.768	0.97	1.08	1.31	1.5	1.8	2.24	2.65	2.83			
2	4	0.399	0.564	0.69	0.796	0.889	1.12	1.25	1.52	1.74	2.11	2.65	3.2	3.46	4		
2.5	5	0.447	0.631	0.722	0.891	0.995	1.25	1.4	1.71	1.96	2.37	3	3.67	4	4.9		
3	6	0.489	0.692	0.846	0.977	1.091	1.38	1.54	1.87	2.15	2.62	3.32	4.08	4.47	5.66	6	
4	8	0.565	0.799	0.978	1.129	1.261	1.59	1.78	2.17	2.5	3.04	3.87	4.8	5.29	6.93	7.75	
5	10	0.632	0.894	1.094	1.262	1.411	1.78	1.99	2.43	2.8	3.41	4.36	5.43	6	8	9.17	
6	12	0.693	0.979	1.198	1.383	1.546	1.95	2.18	2.67	3.07	3.75	4.8	5.99	6.63	8.94	10.39	
7	14	0.748	1.058	1.295	1.495	1.67	2.11	2.36	2.88	3.32	4.05	5.2	6.5	7.21	9.8	11.49	
8	16	0.8	1.131	1.384	1.598	1.786	2.26	2.52	3.08	3.56	4.34	5.57	6.97	7.75	10.58	12.49	
9	18	0.848	1.199	1.468	1.695	1.895	2.39	2.68	3.27	3.77	4.61	5.92	7.42	8.25	11.31	13.42	
10	20	0.894	1.264	1.548	1.787	1.997	2.52	2.82	3.45	3.98	4.86	6.24	7.84	8.72	12	14.28	

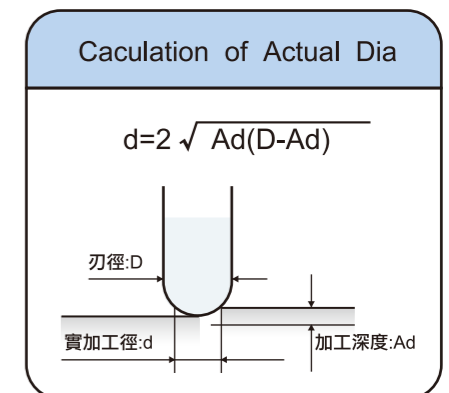

【注意】【NOTE】

- 1) 溝加工時之進給速度，請設定為上數值之60%。  
When slotting, reduce the feed by 60% from above values.
- 2) 請使用油霧(Oil-mist)冷卻或吹氣方式(Air blow)進行切削。  
Use Oil-mist coolant or Air blow.
- 3) 機械設備或工件的夾持剛性不足、出現震動時，請以相同比例按上表降低回轉數及進給速度。  
If the rigidity of the machine or the work material installation is very low, or chattering is generated, please reduce the revolution and the feed rate proportionately.
- 4) 請使用較具有剛性之機械設備及夾頭。  
Use a rigid machine and holder.

切削條件表 Standard Cutting Conditions

SE.RTA

被削材 Work Material	炭素鋼 合金鋼(~30HRC) Carbon steel, Alloy steel S50C, SCM, 鑄鐵 FC250等 AISI 1049, Cast iron			合金鋼 工具鋼(30~45HRC) Alloy steel, Tool steel 預硬鋼, SKD61, NAK等 Pre-hardened steel, AISI H13			沃斯田鐵系列不鏽鋼 Austenitic stainless steel SUS304, SUS316等 AISI 304, AISI 316			熱處理鋼(45~55HRC) Hardened steel SKD61, SKD11, NAK, STAVAX等 AISI H13			銅 Copper											
	50~100 m/min			50~70 m/min			30~60 m/min			20~40 m/min			80~150 m/min											
直徑 (mm) Diameter	回轉數 (min <sup>-1</sup> ) Speed	進給速度 mm/min Feed Rate		回轉數 (min <sup>-1</sup> ) Speed	進給速度 mm/min Feed Rate		回轉數 (min <sup>-1</sup> ) Speed	進給速度 mm/min Feed Rate		回轉數 (min <sup>-1</sup> ) Speed	進給速度 mm/min Feed Rate		回轉數 (min <sup>-1</sup> ) Speed	進給速度 mm/min Feed Rate										
		側面 Side Milling	溝 Slotting		側面 Side Milling	溝 Slotting		側面 Side Milling	溝 Slotting		側面 Side Milling	溝 Slotting		側面 Side Milling	溝 Slotting									
0.2	40,000	—	120	40,000	—	100	28,000	—	60	32,000	—	25	40,000	90	30									
0.3	40,000	—	160	40,000	—	120	28,000	—	70	32,000	—	35	40,000	130	40									
0.4	40,000	—	200	40,000	—	160	28,000	—	90	24,000	—	35	40,000	170	55									
0.5	40,000	320	250	40,000	240	190	25,000	200	120	19,000	75	60	40,000	210	70									
0.6	38,000	380	300	33,000	270	210	21,000	220	130	16,000	75	60	40,000	245	85									
0.7	36,000	420	330	28,000	300	240	18,000	240	140	14,000	75	60	40,000	285	95									
0.8	34,000	480	380	25,000	340	270	16,000	260	150	12,000	75	60	40,000	330	110									
0.9	32,000	540	430	22,000	370	290	14,000	280	160	10,600	75	60	40,000	375	125									
1	30,000	600	480	20,000	400	320	12,600	300	180	9,600	75	60	40,000	420	140									
1.5	20,000	600	480	14,000	400	320	8,400	300	180	6,400	75	60	32,000	800	270									
2	15,000	600	480	10,000	400	320	6,300	300	180	4,800	75	60	24,000	1,000	330									
2.5	12,000	600	480	8,200	400	320	5,100	300	180	3,800	75	60	19,000	1,000	330									
3	10,000	600	480	7,000	400	320	4,200	300	180	3,200	75	60	16,000	1,000	330									
4	7,500	600	480	5,200	400	320	3,100	300	180	2,400	75	60	12,000	1,000	330									
5	6,000	600	480	4,200	400	320	2,500	300	180	1,900	75	60	9,600	1,000	330									
6	5,000	600	480	3,500	400	320	2,100	300	180	1,600	75	60	8,000	1,000	330									
8	4,000	520	410	2,800	350	280	1,600	260	150	1,200	65	50	6,000	1,000	330									
10	3,200	450	360	2,200	300	240	1,300	230	130	1,000	65	50	4,800	1,000	330									
12	2,700	410	320	1,900	270	210	1,100	210	120	800	65	50	4,000	1,000	330									
切削量基準 Depth of cut (D:直徑 Dia.)	$\leq 0.1D (D \leq \phi 3)$ $\leq 0.2D (D > \phi 3)$						$\leq 1.5D$						$\leq 0.02D$ $\leq 1D$											
													$\leq 0.1D (D < \phi 2)$ $\leq 0.2D (D \leq \phi 2)$						$\leq 0.02D (D < \phi 0.5)$ $\leq 0.05D (\phi 0.5 \leq D \leq \phi 2)$ $\leq 0.1D (D > \phi 2)$					

【注意】【NOTE】

- 1) 切削 55~60 HRC 的材料時，請使用4刃或6刃 (SE4或MS6P等) 銑刀。  
Please Use SE4 or MS6P for work materials of 55~60 HRC.
- 2) 切削沃斯田鐵系列不鏽鋼時，請使用非水溶性切削油效果較好。  
In Cutting Austenitic stainless steels, the use of non-water-soluble cutting fluid is especially effective.
- 3) 機械設備或工件的夾持剛性不足、出現震動時，請以相同比例按上表降低回轉數及進給速度。  
If the rigidity of the machine or the work material installation is very low, or chattering is generated, please reduce the revolution and the feed rate proportionately.
- 4) 縱向進給時，進給速度請設定為上表之1/3以下。  
When drilling, please set feed rate at 1/3 or below of the above value.

高速切削條件表 High-Speed Milling Conditions

SE.RTA

被削材 Work Material	炭素鋼, 合金鋼(~30HRC) Carbon steel, Alloy steel S50C, SCM, 鑄鐵 FC250等 AISI 1049, Cast iron			合金鋼, 工具鋼(30~45HRC) Alloy steel, Tool steel 預硬鋼, SKD61, NAK等 Pre-hardened steel, AISI H13			熱處理鋼(45~55HRC) Haydened steel SKD61, SKD11, NAK, STAVAX等 AISI H13		
	300 m/min			200 m/min			100 m/min		
直徑 (mm) Diameter	回轉數 (min <sup>-1</sup> ) Speed	進給速度 mm/min Feed Rate		回轉數 (min <sup>-1</sup> ) Speed	進給速度 mm/min Feed Rate		回轉數 (min <sup>-1</sup> ) Speed	進給速度 mm/min Feed Rate	
		側面 Side Milling	溝 Slotting		側面 Side Milling	溝 Slotting		側面 Side Milling	溝 Slotting
1	40,000	800	640	30,000	600	480	30,000	240	190
2	40,000	1,600	1,280	30,000	1,200	960	15,900	240	190
3	30,000	1,800	1,440	21,200	1,200	960	10,600	240	190
4	28,000	1,900	1,520	15,900	1,200	960	7,900	240	190
5	19,000	1,900	1,520	12,700	1,200	960	6,300	240	190
6	15,000	1,900	1,520	10,600	1,200	960	5,300	240	190
8	11,000	1,550	1,240	7,900	990	790	4,000	220	175
10	9,500	1,330	1,060	6,300	860	680	3,200	200	160
12	7,900	1,200	960	5,300	750	600	2,600	200	160
切削量基準 Depth of cut (D:直徑 Dia.)									

# ERVD 高效能防震

ERVD High-efficiency & Anti-Vibration

## 鎢鋼立銑刀

tungsten Carbide end mills



MIT 製造

$\alpha \neq \beta$  A  $\neq$  B



▶ 極佳的加工垂直度

Process with Excellent Verticality.

▶ 不等分及不等螺旋的設計能最大限度地減少  
高效穩定銑削時的振動

Variable pitch & variable helix designed will minimize vibration on stable milling under highly efficient.

▶ 工作效率提升30%~100%

Improves the working efficiency up to 30%~100%.

▶ 刀具壽命提升50%

Tool service life will up to 50%.



應用材質：難切削材、不鏽鋼、鈦合金、合金鋼、一般鋼材  
預硬鋼材、銅合金、鋁合金、耐熱合金鋼

產品編號：2D ERVD 1004GRJ

影片加工材料：SUS304



**HD.**MIT  
Hwe Der & Ho Dung

### Spindle Speed Table 主軸速度表

直徑 Mill Dia mm	切削速度 V Cutting Speed (mm/min)														
	20	30	40	50	60	70	80	90	100	120	150	180	200	250	300
0.5	12740	19110	25480	31850	38220	44590	50960	57320	63690	70060	76430	82800	89170	95540	101910
0.6	10620	15920	21230	26540	31850	37150	42460	47770	53080	58390	63700	69010	74320	79630	84940
0.7	9100	13650	18200	22750	27300	31850	36400	40950	45500	50050	54600	59150	63700	68250	72800
0.8	7960	11940	15920	19900	23880	27870	31850	35830	39810	43790	47770	51750	55730	59710	63690
0.9	7080	10620	14150	17690	21230	24770	28310	31850	35390	38930	42470	46010	49550	53090	56630
1	6370	9550	12740	15920	19110	22290	25480	28660	31850	35040	38220	41410	44600	47790	50980
2	3180	4780	6370	7960	9550	11150	12740	14330	15920	19110	22300	25490	28680	31870	35060
3	2120	3180	4250	5310	6370	7430	8490	9550	10620	12740	15920	19110	22300	25490	28680
4	1590	2390	3180	3980	4780	5570	6370	7170	7960	9550	11940	14330	16720	19110	21500
5	1270	1910	2550	3180	3820	4460	5100	5730	6370	7640	9550	11460	13370	15280	17190
6	1060	1590	2120	2650	3180	3720	4250	4780	5310	6370	7960	9550	11140	12730	14320
8	800	1190	1590	1990	2390	2790	3180	3580	3980	4780	5970	7170	8370	9570	10770
10	640	960	1270	1590	1910	2230	2550	2870	3180	3820	4780	5730	6680	7630	8580
12	530	800	1060	1330	1590	1860	2120	2390	2650	3180	3980	4780	5580	6380	7180
14	450	680	910	1140	1360	1590	1820	2050	2270	2730	3410	4090	4770	5450	6130
15	420	640	850	1060	1270	1490	1700	1910	2120	2550	3180	3820	4450	5080	5710
16	400	600	800	1000	1190	1390	1590	1790	1990	2390	2990	3580	4170	4760	5350
20	320	480	640	800	960	1110	1270	1430	1590	1910	2390	2870	3350	3830	4310
25	250	380	510	640	760	890	1020	1150	1270	1530	1910	2290	2670	3050	3430

### 換算公式 Reduction Formula

$$V = \frac{\pi DN}{1000} \quad F = N \times Z \times f$$

<b>V</b>	切削速度	Cutting Speed (m/min)
	圓周率	Circular Constant (3.14)
<b>D</b>	銑刀直徑	Diameter (mm)
<b>N</b>	轉速	RPM (min <sup>-1</sup> )
<b>Z</b>	銑刀刃數	Number of Flutes
<b>f</b>	每刃進給	Feed per Tooth (mm/tooth)
<b>F</b>	進給	Feed (m/min)